

**2006 Edition  
International Luge Regulations  
Artificial Track**

|            |   |    |
|------------|---|----|
| <b>§ 1</b> | <b>General Regulations</b> .....  | 3  |
| <b>§ 2</b> | <b>FIL Competitions, Award</b>  |    |
|            | 1. FIL Competitions .....   | 5  |
|            | 2. Procedure for the Award of FIL Competitions .....                      | 5  |
| <b>§ 3</b> | <b>Competition Regulations</b>  |    |
|            | 1. Disciplines.....   | 6  |
|            | 2. Competitions Runs.....   | 6  |
|            | 3. Regulations for Eligibility .....                                      | 6  |
|            | 4. Age Requirements .....   | 6  |
|            | 5. Seeded Groups.....   | 7  |
|            | 6. Competition Program .....  | 8  |
|            | 7. Cancellations, Competition Timeplan .....                              | 10 |
|            | 8. Authorization to Participate in Training.....                          | 10 |
|            | 9. Authorization to Participate in Competition.....                       | 10 |
|            | 10. Rankings .....  | 10 |
| <b>§ 4</b> | <b>Race Administration, Jury, Technical Delegate, International Judge</b> |    |
|            | 1. Race Administration.....   | 12 |
|            | 2. Jury.....  | 13 |
|            | 3. Technical Delegate.....  | 13 |
|            | 4. Combined Task of the Jury and Technical Delegates.....                 | 14 |
|            | 5. International Judge .....  | 14 |
| <b>§ 5</b> | <b>Sled and Equipment</b>   |    |
|            | 1. General Regulations on Sled .....                                      | 15 |
|            | 2. General Regulations on Equipment .....                                 | 20 |
| <b>§ 6</b> | <b>Medical Service</b> .....  | 24 |
| <b>§ 7</b> | <b>Advertising Regulations</b>  |    |
|            | 1. Applicability, Measuring Procedure.....                                | 25 |
|            | 2. Race Clothing.....   | 25 |
|            | 3. Safety Helmet.....   | 25 |
|            | 4. Goggles/Visor.....   | 25 |
|            | 5. Caps, Headbands and other Headgear.....                                | 25 |
|            | 6. Start Numbers .....  | 26 |
|            | 7. Racing Shoe .....  | 26 |
|            | 8. Gloves .....   | 26 |
|            | 9. Racing Sled .....  | 26 |
|            | 10. Athlete.....  | 26 |
|            | 11. Forbidden Advertising.....  | 26 |
| <b>§ 8</b> | <b>Training, Weigh-in, Individual Supplemental Weights</b>                |    |
|            | 1. International Training Courses .....                                   | 27 |
|            | 2. Paid Training.....   | 27 |
|            | 3. Official Training.....   | 27 |
|            | 4. Weigh-In .....   | 29 |
|            | 5. Individual Supplemental Weights .....                                  | 30 |

|                     |  |    |
|---------------------|--|----|
| <b>§ 9</b>          | <b>Race Preparation</b>                                    |    |
|                     | 1. Entries .....   | 31 |
|                     | 2. Entry Fee .....   | 31 |
|                     | 3. Draw.....   | 31 |
| <b>§ 10</b>         | <b>Start, Finish, Timing, Results</b>                      |    |
|                     | 1. Start.....  | 33 |
|                     | 2. Controls at the Start.....                              | 33 |
|                     | 3. Finish .....  | 35 |
|                     | 4. Controls at the Finish .....                            | 35 |
|                     | 5. General Rules .....                                     | 35 |
|                     | 6. Timing.....   | 37 |
|                     | 7. Results.....  | 37 |
| <b>§ 11</b>         | <b>Protests</b>  |    |
|                     | 1. Reason for a Protest.....                               | 38 |
|                     | 2. Procedure .....   | 38 |
|                     | 3. Settlement.....   | 38 |
| <b>§ 12</b>         | <b>Awarding of Titles, Awards Ceremony</b>                 |    |
|                     | 1. Titles for World Championships .....                    | 39 |
|                     | 2. Titles for Continental Championships.....               | 39 |
|                     | 3. Awarding of Titles in Case of a Reduction of Runs ..... | 39 |
|                     | 4. Certificates .....                                      | 39 |
|                     | 5. Medals.....   | 39 |
|                     | 6. Pins for Competitors and Officials.....                 | 40 |
|                     | 7. Gifts of Honor and Mementos.....                        | 40 |
|                     | 8. Awards Ceremony and Conclusion of the Event .....       | 40 |
| <b>§ 13</b>         | <b>Concluding Regulations</b> .....                        | 41 |
| <b>Supplements:</b> |  |    |
|                     | 1. Regulation for Artificial Luge Tracks .....             | 42 |
|                     | 2. Individual Weight Allowances .....                      | 45 |
|                     | 3. Rules for Instruction of International Judge .....      | 61 |
|                     | 4. Regulations for Audio-Visual Media Rights .....         | 63 |
|                     | 5. Olympic Rules.....                                      | 65 |

## § 1 General Regulations

1. The International Luge Regulations for Artificial Track (IRO) include the regulations for an orderly staging of all competitions of the sport of luge on artificial tracks including championships and international competitions of the FIL.  
It is also valid for the luge competitions during Olympic Winter Games (OWS)\*, please refer to Supplement 5.
2. The sanctioning body and event organizers as well as the participating nations, sport clubs, teams, athletes, judges and all assigned helpers are obliged to adhere to the following regulations and use them during the staging of competitions on artificial tracks during Olympic Winter Games, FIL Championships and international competitions provided that there are no IOC regulations, FIL statutes or resolutions of FIL bodies ruling against it.
3. Athletes registered by their National Federations (NFs) can participate in all FIL competitions if they have a valid license.  
The licenses are filled out by the respective National Federation on behalf of the FIL and are newly signed by the President of the respective NF or by a person authorized by him/her every season.  
With the signature of the National Federation's representative, it has to be confirmed that
  - ♦ the athlete is a member of his/her federation or one of its associated clubs,
  - ♦ the athlete is insured for practicing the sport of luge also in foreign countries,
  - ♦ the athlete has a medical certificate that is based on a medical examination conducted during the last 12 month or a subsequent medical examination in the event of a serious injury, and states that from a point of view of sports medicine, he/she is fit for practicing the sport of luge, and
  - ♦ the athlete has received such a basic training that one could expect the athlete to be able to master luge tracks used for competitions in a safe way.The license only becomes valid after the athletes declare in writing that they bindingly acknowledge the statutes and regulations of the FIL, especially the IRO, the Law and Procedure Regulations of the FIL and that they have knowledge of the contents of all regulations.  
The license has to be submitted to the race director prior to each competition.  
The event organizer authorized to stage FIL competitions is obligated to conclude a liability insurance for the entire duration of the competition in which the extent of the coverage is to be regulated through a written agreement.  
Any liability of the FIL will be explicitly excluded.
4. All national federations have the right to apply for the staging of FIL Championships and international competitions according to the regulations of the IRO.  
With the application to host an event, the respective National Federation acknowledges the IRO regulations and all other FIL regulations.  
Deviations from these regulations only become effective if they are explicitly approved by the FIL bodies responsible according to the statutes.
5. Athletes, FIL officials, National Federations, physicians, coaches, managers and other participants in the sport of luge are obligated to comply to the Anti-Doping Code of the FIL during and outside competitions.
6. Each participating athlete and official must behave fairly and in a sportsmanship like manner during a competition.
7. In case of discrepancies between the text of the IRO and the text of other FIL regulations or instructions of FIL bodies, the regulations of the IRO are decisive unless previous regulations of the FIL statutes state otherwise.

8. The word „athlete“ used in the IRO includes both female and male competitors.
9. The sport's year of the FIL starts on July 1st and ends on June 30th of the following year.
10. Violations against the regulations of the IRO result in disqualifications and/or other sanctions, which are specified in the Law and Procedure Regulations.

\* Although this version is a translation from the German, the abbreviations in general are not changed, so that consistency might be maintained.

**1. FIL Competitions**

**1.1 Luge competitions during Olympic Winter Games (OWS)**

**1.2 FIL Championships, Rotation**

**1.2.1 World Championships (WM)**

- ♦ in each sport's year, with the exception of the year in which the OWS will be staged

**1.2.2 Continental Championships**

- ♦ in same sport's year as OWS will be staged and respectively two sport's years later

**1.2.3 Junior World Championships (JWM)**

- ♦ in each sport's year

The Championships are numbered in a continuous order even if awarded championships are cancelled:

39<sup>th</sup> WM 2007  
22<sup>nd</sup> JWM 2007  
41<sup>st</sup> EM 2008

**1.3 International Competitions**

**1.3.1 World Cup (WC)**

The staging of World Cup races in blocks is allowed (i.e. three World Cup races in two weeks).

**1.3.2 Junior World Cup (JWC)**

- ♦ 6 races

**1.3.3 Nations Cup (NC)**

World Cup and Nations Cup are staged in one event.

**1.3.4 Three-Tracks Tournament (Dreibahnen-Tournee DT)**

**1.3.5 FIL Youth Games**

**1.3.6 Other international competitions**

**2. Procedure for the award of FIL Competitions**

**2.1 The FIL Congress awards the FIL Championships a maximum of 4 years in advance.**

The award is made upon written application by the National Federation.

The application according to the current form has to be submitted to the President of the FIL twelve weeks prior to the Congress.

**2.2 The Executive Board awards the World Cup races with corresponding bidding criteria upon application by the National Federations.**

**2.3 All other FIL competitions are confirmed by the Executive Board.**

**§ 3 Competition Regulations**

**1. Disciplines**

- 1.1 FIL competitions are staged in the following disciplines:
- ♦ Women - Singles
  - ♦ Men - Singles
  - ♦ Doubles
  - ♦ Team competition (§ 3 Point 6.4)
- 1.1.1 The team competition is obligatory during FIL Championships.

**2. Competition Runs**

|                            | Singles | Doubles | Team |
|----------------------------|---------|---------|------|
| FIL Championships          | 2       | 2       | 1    |
| International Competitions | 2       | 2       | 1    |

- 2.1 By the cancellation of a run, disqualifications and eliminations as a result of a crash that have occurred during this run are not valid.

**3. Regulations for Eligibility**

|   | Women                    | Men | Doubles | Team Competition |
|---|--------------------------|-----|---------|------------------|
| 3.1 FIL Championships                             | 4                        | 4   | 3       | 1 team           |
| 3.2 World Cup                                     | 4                        | 5   | 3       | 1 team           |
| 3.3 Nations Cup                                   | refer to § 3 Point 6.2.2 |     |         |                  |
| Additional starters allowed for NC                | 2                        | 3   | 2       |                  |
| Additional starters will not be awarded WC points |                          |     |         |                  |

During World and Continental Championships in the General Class, the title holders have a right to start (in the doubles discipline, only the team which had won the title).

- 3.4 For Junior World Cups, the following is applicable:

|                 | Youth A | Junior | Together   |
|-----------------|---------|--------|------------|
| Men's singles   | 6       | 6      | maximum 10 |
| Women's singles | 5       | 5      | maximum 8  |
| Doubles         |         |        | 3          |

**4. Age Requirements**

- 4.1 FIL competitions are staged in the following age classes:
- ♦ General Class
  - ♦ Juniors
  - ♦ Youth A
  - ♦ Youth B
  - ♦ Youth C
  - ♦ Youth D
  - ♦ Seniors

- 4.2 Athletes who compete in youth and junior competitions must belong to the following age classes:
- |         |             |                    |
|---------|-------------|--------------------|
| Juniors | Maximum Age | Year of Event - 20 |
|         | Minimum Age | Year of Event - 18 |
| Youth A | Maximum Age | Year of Event - 17 |
|         | Minimum Age | Year of Event - 15 |
| Youth B | Maximum Age | Year of Event - 14 |
|         | Minimum Age | Year of Event - 13 |
| Youth C | Maximum Age | Year of Event - 12 |
|         | Minimum Age | Year of Event - 11 |
| Youth D | Maximum Age | Year of Event - 10 |
- (minimum age and maximum age = age class)
- 4.2.1 During a competition taking place at the beginning of the season (July 1st - December 31st), the athlete belongs to the age class valid for him/her during a competition starting on the following 1st of January.
- 4.2.2 During JWC, athletes belonging to the Youth Class B are eligible to start in the Youth Class A. They can start with a 14 kg youth sled (singles) and with a 22 kg youth sled (doubles).
- 4.2.3 The Youth Classes B, C and D may only start with a youth sled in their classes.
- 4.3 For the OWS, FIL Championships and international competitions in General Class, athletes must have reached their fifteenth (15th) birthday during the sport's year.
- 4.4 During the staging of competitions for seniors, athletes must have reached their 35th birthday.
- 5. Seeded Groups**
- 5.1 During FIL competitions, seeded groups will start in all disciplines in the General Class and Junior Class except in the team competition.
- 5.2 **Composition of seeded groups at FIL Championships and World Cup races**  
 Group A = 15 men, 10 women and 8 doubles as per name  
 Group B = 15 men, 10 women and 8 doubles  
 Group C = 15 men, 10 women and 8 doubles  
 The names of athletes from the seeded groups are to be confirmed by the team captain before each draw.
- 5.2.1 Depending on the number of athletes, the groups A, B, and C will always be formed in each discipline.
- 5.3 **Composition of seeded groups at Junior World Championships and Junior World Cups**  
 Group A = fifteen (15) athletes and/or double teams as per name  
 Group B = athletes and/or double teams with JWC points as per NF  
 Remaining group = athletes and/or double teams without JWC points as per NF  
 The names of athletes from the seeded groups are to be confirmed by the team captain before each draw.  
 Exception for Junior World Championships:  
 Group A = fifteen (15) athletes and/or double teams as per name, one of these athlete/double team as per NF.
- 5.4 **Calculation of seeded places**  
 The current positions in the seeded groups A, B and C result from the World Cup point ranking of the three previous World Cup races.  
 For the Junior Class, the current positions in the seeded groups A and B result from the current Junior World Cup point ranking.  
 For the 1<sup>st</sup> Junior World Cup race, the overall Junior World Cup ranking of the previous season is valid.  
 Beginners will start in the remaining group.

- 5.5 The seeded groups will generally be filled up to their full number.  
In the absence of an athlete, the next ranked athlete moves up. In the Junior Class, this is only valid for the A group.

**6. Competition Program**

**6.1 FIL Championships in General Class**

In all disciplines, the 1<sup>st</sup> race run will start in the order of the current seeded list as follows:

- ◆ Remaining group, starting with the athlete who has the fewest points.
- ◆ Group C, starting with the athlete who has the fewest points.
- ◆ Group B, starting with the athlete who has the fewest points.  
If athletes are level on points in these groups, the start order is determined by a draw.
- ◆ Group of athletes who have not yet competed in this season.  
The start order within this group is determined by a draw.
- ◆ Group A  
The start order within this group is determined by a draw.  
Before the start of Group A, the track will be sprayed.

In all disciplines, the start order in the 2<sup>nd</sup> race run is as follows:

- ◆ Last place to 1<sup>st</sup> place according to the placing of the first race run.
- ◆ Before the start of the top 15 athletes, the track will be sprayed.

**6.2 World Cup in General Class / Nations Cup**

**6.2.1 Qualification / Nations Cup**

Nations Cup and Qualification for the World Cup race will be carried out in one run.  
The qualification will take place if more than 17 men, 14 women and 8 doubles (without additional starters) are at the start.

**6.2.2 Participation**

Athletes of the seeded group A do not participate in the Qualification / Nations Cup.  
For all other athletes (not for additional starters), the Nations Cup is considered as the qualification for the World Cup.

**6.2.3 Start Order for Qualification / Nations Cup**

The start order arises from the current list of seeded groups.

The first ones to start are:

- Men - 16<sup>th</sup> place to the end
- Women - 11<sup>th</sup> place to the end
- Doubles - 9<sup>th</sup> place to the end

Afterwards, athletes who do not come from the seeded list will start. These athletes will be drawn.  
Additional starters will be placed at the end of the start list according to a draw.

**6.2.4 Qualification for World Cup races**

The fastest 17 men, 14 women and 8 doubles will qualify for participation in World Cup races.  
Additional starters can not qualify for the World Cup race.

**6.2.5 Participation at World Cup races**

|                    | Men | Women | Doubles |
|--------------------|-----|-------|---------|
| Seeded Group A     | 15  | 10    | 8       |
| Qualification / NC | 17  | 14    | 8       |

The size of the field will be adjusted only by a tie in points or placing.



- 6.2.6 Start Order for World Cup races  
 1<sup>st</sup> competition run
- ◆ Last place to best place from the Qualification
  - ◆ Seeded group A according to draw
- 2<sup>nd</sup> competition run
- ◆ According to the results of the 1<sup>st</sup> competition run: last place to first place.
- If there is no Nations Cup / Qualification, than
- 1<sup>st</sup> competition run
- ◆ Last place to seeded group B from current seeded list
  - ◆ Seeded group A according to draw
  - ◆ Athletes without World Cup points according to a draw
- 2<sup>nd</sup> competition run
- ◆ According to the results of the 1<sup>st</sup> competition run: last place to first place.
- 6.2.7 Nations Cup: Allocation of World Cup points for non-qualified athletes  
 Non-qualified athletes are awarded the following World Cup points:  
 Men: 18<sup>th</sup> place in Nations Cup - 8 World Cup points etc. according to list in § 3 Point 10.1  
 Women: 15<sup>th</sup> place in Nations Cup - 16 World Cup points etc. according to list in § 3 Point 10.1  
 Doubles: 9<sup>th</sup> place in Nations Cup - 24 World Cup points etc. according to list in § 3 Point 10.1  
 If the size of the World Cup field is adjusted (see point 6.2.5), then points awarded to Nations Cup athletes will be adjusted accordingly.  
 Additional starters will not be awarded any World Cup points.
- 6.3 **JWM, JWC, other International Competitions in Junior Class / Youth**  
 In all disciplines, the 1st run will start in the order of the drawn start numbers where the number of athletes is divided into seeded groups A, B and in a remaining group.  
 The second race run will be carried out in all three disciplines as follows:
- ◆ Last place to first place according to ranking after the first race run
- 6.4 **Team Competition Program**
- 6.4.1 Eligibility to participate  
 Only one complete team per nation may participate in the competition (one man, one woman, one doubles).  
 Exception in Junior Class:  
 Two nations that can not have its own team may come together to form a team.  
 A NF that has one team can not be represented with athletes in a second team.
- 6.4.2 Registration for team competition  
 Registration has to take place by name at the last team captains' meeting.  
 Substitution is possible for justified reasons, e.g. injury or illness of an athlete.
- 6.4.3 Time of competition  
 The FIL determines the time when the competition must be staged by the event organizer.
- 6.4.4 Additional training run  
 If the team competition is held before the individual disciplines, athletes who have not participated in the team competition could receive an additional training run.  
 The decision is made by the race director after consultation with the jury.
- 6.4.5 Order of nations  
 The order of nations will be drawn.  
 First discipline - Start number 1 to end  
 Second discipline - End to start number 1  
 Third discipline - According to intermediate ranking beginning with last ranked team.  
 The order of the individual disciplines is variable.
- 6.4.6 For the calculation of results and overall results of the team competition, refer to Point 10.5.

**7. Cancellations, Competition Timeplan**

- 7.1 The race director is authorized in agreement with the jury and the technical delegate, to adapt the start order of the race runs to television requirements and weather conditions in order to ensure a fair race for everybody involved.
- 7.2 The race director can decide to cancel a discipline upon consultation with the technical delegates.

**8. Authorization to participate in training**

An athlete is authorized to participate in training if

- ♦ he/she fulfills the general athletic demands of the sport and has successfully completed a FIL luge school. The confirmation is provided by the responsible FIL coach. If in doubt, an athletics test will be carried out by the responsible FIL coach, the minimum requirements of which must be fulfilled.
- ♦ he/she has not started for another nation during the respective sport year,
- ♦ a valid license is submitted,
- ♦ the age class regulations are adhered to,
- ♦ he/she has been registered for the competition in correspondence with the regulations for eligibility under § 3 Point 3. (Exception: Athletes who do not participate in the competition, but start as forerunners).

**9. Authorization to participate in competition**

An athlete is authorized to participate in a competition, if

- ♦ he/she participated in the training,
- ♦ he/she achieved a time difference of up to a maximum of 7% from the group's best time in one of his/her official training runs in the respective group (not valid for Juniors),
- ♦ he/she does not participate as an official in this competition.

**10. Rankings**

**10.1 World Cup**

For the results achieved in a World Cup competition, the following points per race are awarded:

Men / Women / Doubles:

|            |            |            |           |            |                |
|------------|------------|------------|-----------|------------|----------------|
| 1st Place  | 100 Points | 15th Place | 26 Points | 29th Place | 12 Points      |
| 2nd Place  | 85 Points  | 16th Place | 25 Points | 30th Place | 11 Points      |
| 3rd Place  | 70 Points  | 17th Place | 24 Points | 31st Place | 10 Points      |
| 4th Place  | 60 Points  | 18th Place | 23 Points | 32nd Place | 9 Points       |
| 5th Place  | 55 Points  | 19th Place | 22 Points | 33rd Place | 8 Points       |
| 6th Place  | 50 Points  | 20th Place | 21 Points | 34th Place | 7 Points       |
| 7th Place  | 46 Points  | 21st Place | 20 Points | 35th Place | 6 Points       |
| 8th Place  | 42 Points  | 22nd Place | 19 Points | 36th Place | 5 Points       |
| 9th Place  | 39 Points  | 23rd Place | 18 Points | 37th Place | 4 Points       |
| 10th Place | 36 Points  | 24th Place | 17 Points | 38th Place | 3 Points       |
| 11th Place | 34 Points  | 25th Place | 16 Points | 39th Place | 2 Points       |
| 12th Place | 32 Points  | 26th Place | 15 Points | 40th Place | 1 Point        |
| 13th Place | 30 Points  | 27th Place | 14 Points | 41st Place | and continuing |
| 14th Place | 28 Points  | 28th Place | 13 Points |            | with 1 point   |
|            |            |            |           |            | each           |

- ◆ For World Cup ranking, no results can be dropped.
- ◆ In doubles, the teams are ranked.
- ◆ If a doubles team starts again with another athlete, this new team will be ranked separately.
- ◆ The World Cup champions will be the athletes who have accumulated the highest number of points.
- ◆ Ties are awarded the same rank.

Athletes/Teams that are listed as a DNS for a specific event will not be recorded in the World Cup rankings for that event.

Athletes/Teams that are listed as a DNF or DSQ for a specific event will be shown in the rankings as either DNF or DSQ as the case may be.

#### Nations Ranking

For the nations ranking, the points of all athletes from a National Federation are added according to the overall World Cup ranking.

#### 10.2 **Junior World Cup**

Ranking like World Cup.

#### 10.3 **Nations Cup**

Allocation of World Cup points refer to § 3 Point 6.2.7.

#### 10.4 **Three-Tracks Tournament (Dreibahnen-Tournee)**

Ranking like World Cup.

#### 10.5 **Team Competition**

The results of the team competition are based on the total cumulative time of the three sleds.

Overall rankings of nations will be made at the end of all competitions.

The points will be allocated according to the World Cup rankings.

Should there be a tie between two or more teams, the times from all competitions will be added and ranked accordingly.

**1. Race Administration**

The race administration includes the race director, start leader, finish leader, and chief of track.

**1.1 Race Director**

1.1.1 The race director is fully responsible for the staging of the competition.

1.1.2 For training and competition, the race director declares the track open, if

- ♦ the confirmation by the chief of track and the technical delegates has been submitted,
- ♦ all officials have taken their posts and the technical equipment has been found to be in working order after examination and/or testing,
- ♦ the facilities for the communication are available and at least the phone connection between start and finish is in working order,
- ♦ the medical service is available.

1.1.3 If the jury or the technical delegates detect deficiencies which influence the orderly staging of the event, the race director has to have the deficiencies remedied.

1.1.4 If accidents occur or if the technical equipment fails, the race director closes the track until proper continuation of the event is guaranteed.

1.1.5 The race director has the right to refer an athlete to the race doctor for a medical assessment if this athlete is injured or ill or if for any other reason, his/her start involves a specific risk to his/her health or life.

If the race doctor confirms a specific risk to the health or life of the athlete in writing, the race director is entitled to withdraw the permission to start in official training and/or competition from an athlete (§ 6 Point 2).

1.1.6 The race director must inform the chairperson of the jury and the technical delegates of all incidents.

1.1.7 In case of violations against the IRO, the race director will make the initial necessary decisions.

He/she is obligated to personally convince himself/herself of the offence.

Items or corresponding pieces of evidence for a possible disqualification must be submitted to him/her by the judges, jury and respective technical delegate.

**1.2 Start Leader**

1.2.1 The start leader is responsible for overall supervision of the start area.

He/she is in charge of testing and weighing of the sled and equipment of the athletes and is to supervise the start process.

1.2.2 The start leader shall immediately notify the race director of any infraction of the rules.

**1.3 Finish Leader**

1.3.1 The finish leader is responsible for coordination of all activities including the staging of the competition at the finish area as well as for the proper running of timing and controls at the finish.

1.3.2 The finish leader shall immediately notify the race director of any infraction of the rules.

**1.4 Chief of Track**

1.4.1 The chief of track is responsible for flawless maintenance of the track during training and competition.

He hands over the track to the technical delegate.

1.4.2 He/she must immediately report reasons against use of the track to the race director.

1.4.3 The chief of track has to take care that the ice temperature during a competition run is kept constant by at least - 3° Celsius in the shadow.

The technical delegate has to be informed about any changes of the ice temperature due to regulation in the refrigeration plant.

The ice temperature has to be visibly displayed within the start area.

## **2. Jury**

### **2.1 Appointment**

- 2.1.1 The members of the jury for the OWS and FIL Championships will be proposed by the Sport Commission. The Executive Board will make the final decision.
- 2.1.2 The proposed candidates must be members of a National Federation or a Commission (Technical or Sport) and must have an International Judge License.
- 2.1.3 By the staging of an international competition, the authorized National Federation proposes three candidates to the FIL Executive Board.
- 2.1.4 The decision on the appointment to the jury will be confirmed in writing to the National Federation, the event organizer and the nominated judges.

### **2.2 Composition**

- 2.2.1 The jury includes the chairperson and two additional members.
- 2.2.2 At all FIL competitions, the 3 members of the jury must belong to different National Federations.

### **2.3 Duties**

- 2.3.1 The jury is the highest authority present. In accordance with the IRO, it is charged with decision making power for the duration of a competition.
- 2.3.2 Members of the jury are not permitted to assume a technical function or a race official's position during an event.
- 2.3.3 Along with their supervisory duties, the jury makes a decision on all written protests with a simple majority vote.
- 2.3.4 Each member of the jury has access without prior notice to all technical equipment and facilities which are necessary for the staging of an event.
- 2.3.5 The jury must be available from the beginning of training. During Junior World Cups and Nations Cups, the jury should be available for the last training, but they must be available for the draw at the latest.
- 2.3.6 If a jury member is not able to participate, the remaining jury members and the chairperson of the organisation of the competition decide upon the assignment of a new jury member.
- 2.3.7 The chairperson of the jury has to completely fill out the race report and mail it according to the distribution code.

## **3. Technical Delegate**

### **3.1 Appointment**

- 3.1.1 Three technical delegates will be proposed by the Technical Commission for the OWS and FIL Championships (except for FIL Junior World Championships). The Executive Board will make the final decision.
- 3.1.2 For all other FIL competitions (including FIL Junior World Championships), the FIL Executive Board will appoint one permanent technical delegate of the FIL.
- 3.1.3 The organizing NF will appoint another technical delegate. This technical delegate will be responsible for individual tasks given to him/her by the permanent technical delegate, and he/she shall be available to the permanent technical delegate in an assisting function.

### **3.2 Composition**

- 3.2.1 The technical delegates are representatives of the FIL.  
They provide assistance to the event organizers through their expertise and via their supervisory and inspection duties, insure technical observance of the IRO Artificial Track.
- 3.2.2 The technical delegates have to own an International Judge License.
- 3.2.3 The FIL always provides a full-time technical delegate at all competitions (FIL Championships, WC, JWC). This technical delegate may not work for any other National Federation while performing his/her duties during training and competitions.
- 3.2.4 Technical delegates at OWS and FIL Championships must be members of the FIL Executive Board or Expert Commissions. One of the technical delegates should be a member of the FIL Technical Commission.

3.3 **Duties**

- 3.3.1 The technical delegate has access without prior notice to all technical facilities and equipment necessary for the staging of an event.
- 3.3.2 During the days of training, the technical delegates, in agreement with the race director, must grant the National Federations the opportunity to have their sleds and equipment examined.
- 3.3.3 Before each training and competition run, the technical delegates must inspect the track and facilities and will transfer the track to the race director only when the inspection has justified it and when the chief of track has handed the track over to the technical delegate.
- 3.3.4 The jury or the race director is to seek the expert opinion of the technical delegate about various decisions, protests and so forth.

4. **Combined Task of the Jury and Technical Delegates**

Before all competitions, the race director, the chairperson of the jury and technical delegates have to determine the action plan for the jury and the technical delegates.

5. **International Judge**

- 5.1 Only judges possessing an FIL International Judge License may serve in a position of race leadership in FIL competitions.
- 5.2 International judges must officiate a minimum of one competition each sports year and attend repetitive training provided by the National Federations or the FIL once every two years, pertaining to changes in the IRO, to remain active.
- 5.3 International judges who have not officiated a competition or attended repetitive training, pertaining to IRO changes, for a period of five years, will be withdrawn as an international judge and must re-acquire the International Judge License.
- 5.4 The National Federations must provide instruction for judges who wish to acquire the International Judge License or remain active.
- 5.5 National Federations which have no internationally approved judges to carry out FIL competitions must request international judges from the FIL for these competitions. According to the FIL travel cost reimbursement plan, compensation is to be paid by the National Federation which stages the competition.

## § 5 Sled and Equipment

### 1. General Regulations on Sled

- 1.1 The luge sled must have one pair of runners.  
Mechanical braking devices are forbidden.  
The primary components of the sled are:
- ♦ 2 Runners
  - ♦ 2 Blades
  - ♦ Sling seat or pod seat
  - ♦ 2 Bridges
- If the bridge consists of two or more parts, these may not be adjusted or changed during a run.  
If a sled has stabilizer bars, they can not exceed 20 mm in diameter at any point outside of the shell.
- 1.2 The blades must be one solid mass and must not be flexible.
- 1.2.1 The gliding steel, blades and runners of the sled may not include any cushioning and/or suspension.  
This is also valid for individuals parts connecting these items to each other as well as for the fastening of the bolts connecting blade to the runner.  
This ban is not valid for § 5 Point 1.11 attachment of the bridges.  
Inlays between runner and blade are allowed up to 1 mm.  
These inlays must be at least 50 mm long and be placed one behind the other. A continuous inlay can also be used.  
The control of the connection between blade and runner must take place with the measurement starting at a maximum of 50 mm from the begin of the blade and at a maximum of 50 mm from the end of the blade as well as at each bolts connecting the blade to the runner.  
The space to be measured between runner and blade may not be higher than 1.2 mm and space between the individuals inlays may not be longer than 200 mm.  
The area between runner and blade may not be covered.  
Refer to Sketch 1.b for further details.
- 1.3 The weights including attached accessories are:
- \* Minimum 21 kg, maximum 25 kg for a singles sled
  - \* Minimum 25 kg, maximum 30 kg for a doubles sled
  - \* Maximum 14 kg for a youth sled
  - \* Maximum 22 kg for a youth double sled
- The calculation of weight
- \* for a singles sled is 23 kg
  - \* for a doubles sled is 27 kg
- Missing or increased weight of the sled (+/- 2 kg) can be adjusted through the AW.
- ♦ Athletes belonging to the Youth Class B who are starting in the Youth Class A with a 14 kg youth sled (in singles) and a 22 kg youth sled (in doubles) may not adjust the missing weight on the sled through additional weight.
- 1.4 The distance between the inner edges of the blades must not exceed 450 mm at any point (refer to Sketch 5).
- 1.5 The maximum width of the sled, including shell and handles, must not exceed 550 mm at any point (refer to Sketches 2 and 4).
- 1.6 In the interest of safety, the outer edges of the blades including laminate must be rounded or sloped to a radius of at least 5 mm (refer to Sketch 5).

- 1.7 Steering must result from use of the primary components of the sled mentioned in Section 1.1. and may be supplemented by reins and stabilizer bars.  
On a doubles sled, steering may be supplemented by foot supports for the person on the back.
- 1.8 The foot supports for the person on the back of the doubles sled must not be longer than 300 mm. The maximum height of the runner must not exceed 130 mm in this area (Sketch 1a).
- 1.9 Use of an encased seat (pod) on the sled is allowed.  
The seat (pod), including the stabilizer bars and handles, must not be wider than 550 mm or exceed a thickness of 120 mm at any point (at any width).  
In the rear, the seat (pod) must not extend past the shoulders, and in the front, must not extend past the knees of the athlete.  
On a doubles sled, the knees of the person in front and the shoulders of the person at the back will be considered for this measurement.  
The seating position of the doubles athletes has to be one behind the other.  
A terraced seat is permitted.  
The clear height of the pod, measured 90° perpendicular from the plane table, including bars must not exceed 170 mm from the knees of the front man to the terraced seat and 120 mm up to the shoulders of the back man (refer to Sketches 2, 3, and 4).
- 1.10 The dimensions of the runner plus blade must not exceed 50 mm in width and 80 mm in height. The runner must be at least 25 mm wide from the area of the middle of the rear bridge to the middle of the forward bridge.  
Dimensions of the blades within this area are to be 30 mm maximum height and 15 mm minimum width including the required rounding (refer to Sketches 1.a and 5).  
Checking of the runner dimensions is done in a right angle to the vertical and horizontal middle axis of the runner.
- 1.11 The weight of the upper-part of the sled (bridges with pod seat) must be connected all the way through on each leg of the bridge with a screw or a bolt.  
The mobility of the four bridge legs in the area of the screws or bolts is allowed by using a rubber bearing or flexible bearing.  
The diameter of the rubber bearing or flexible bearing may be max. 33 mm and may not be wider than the inside measurement of the boxes.  
Any other cushioning or suspension in this area is not allowed (refer to Sketch 6).
- 1.12 The rubber inserts which cover the leg of the bridge must be open on the bottom so that the stipulated free space is given (refer to Sketch 6).
- 1.13 The drawings serve only as a visual representation of the regulated equipment measurements. They have no significance whatsoever for the testing process or for the construction of the equipment.



1.14 Drawings regarding the sled:

Sketch 1 a

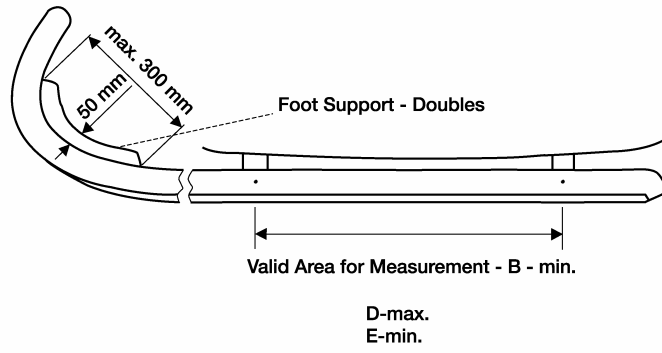

Sketch 1 b

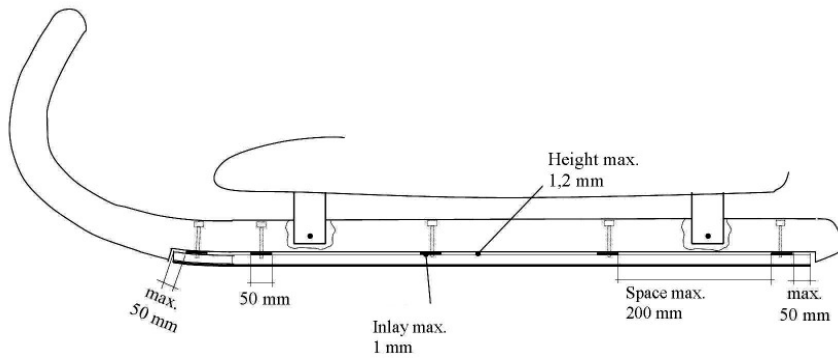

Sketch 2

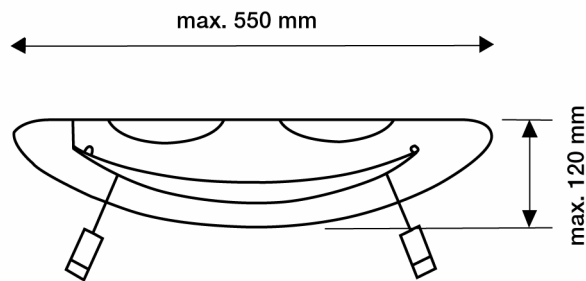

Sketch 3

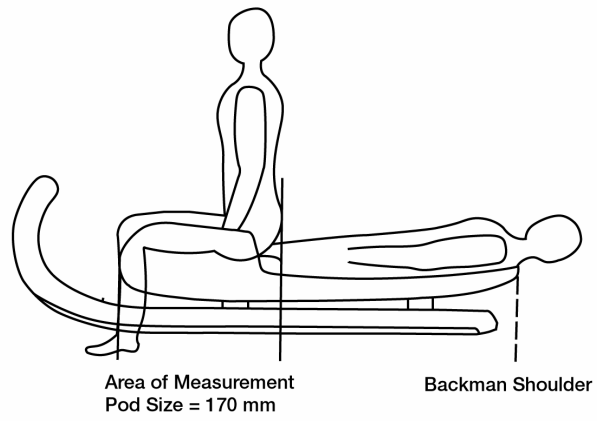

Sketch 4

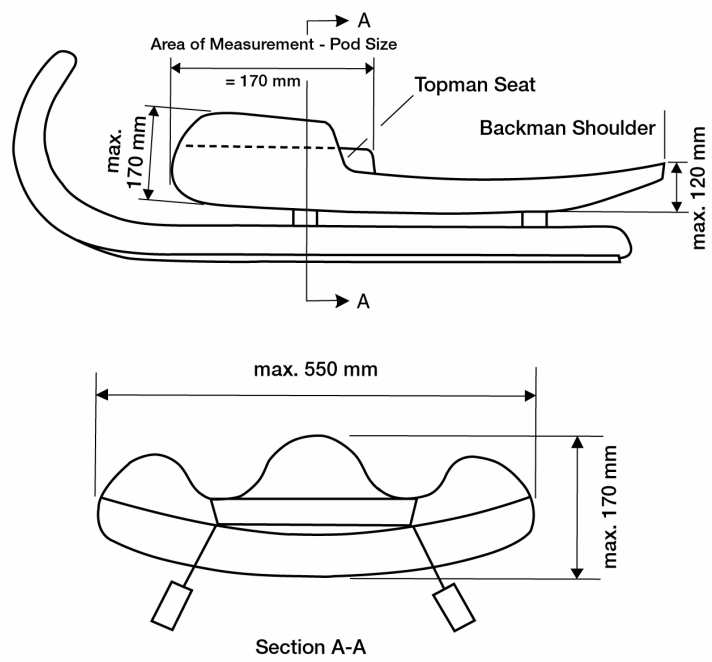

Sketch 5

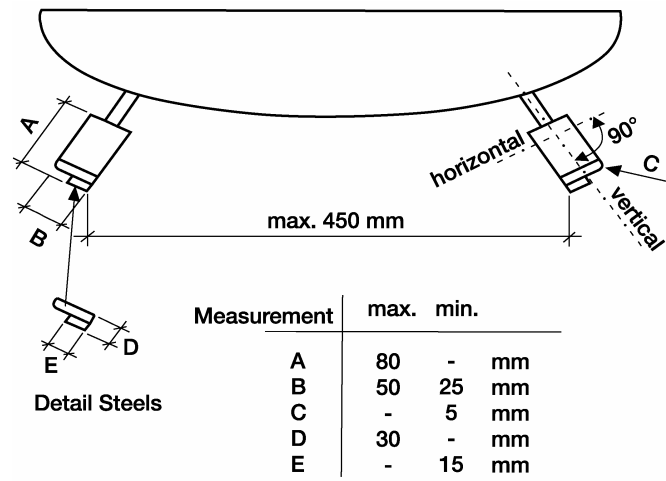

Sketch 6

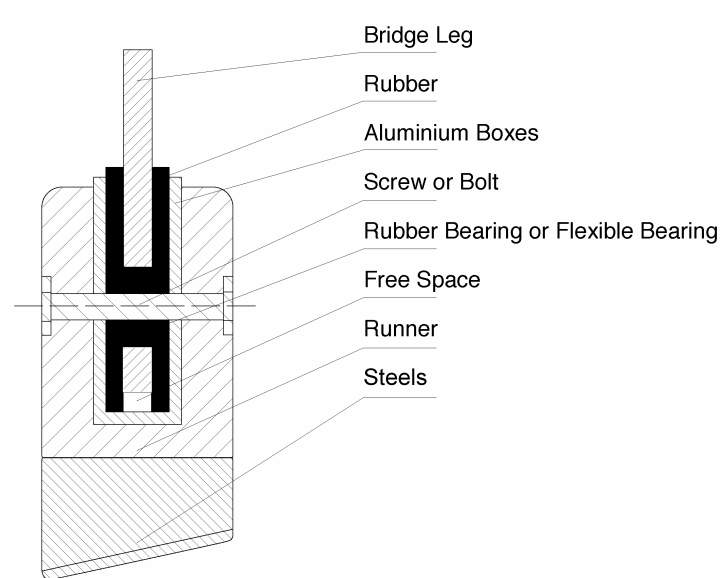

## 2. **General Regulations on Equipment**

### 2.1 **General**

- 2.1.1 All items of race clothing, including helmet and racing shoes, must conform to or be adapted to the body contours of the competitor.  
The wearing of visors is permitted.  
Aerodynamically formed connections between the head and upper body are not permitted.  
A neckstrap is permitted; however, it may not lead to (or cause) an aerodynamically improved form of the race clothing.  
Each competitor must use proper race clothing in training and competition.
- 2.1.2 Additional protective equipment (pad(s)) must conform to the competitor's body contour and is permitted to be a maximum of 10 mm in thickness.

### 2.2 **Gloves**

The effective length of the spikes of the gloves: maximum 4 mm, measured in the axis.  
The fastening of individual spikes must guarantee that each spike must have an edge of at least 2 mm on three sides (refer to Sketch 7).

### 2.3 **Safety Helmet**

Wearing of a safety helmet is mandatory.  
Each athlete who takes part in a FIL competition must wear the official FIL sanctioned helmet.  
The visor is a component of the FIL safety helmet.

### 2.4 **Racing Shoes**

It is mandatory to wear racing shoes (luge shoes).  
The shoe consists of one sole and one shaft (upper part).  
The sole may not be thicker than 20 mm.  
Rounding is allowed.  
The sole of the racing shoes for the backman in doubles can be made thinner and can be produced with a thinner sole.  
The free angle of the shoe must not be less than 50°, measured to the bottom of the shoe when the shoe is not worn.  
The curvature of the sole to the end of the shaft may not be more than 15 mm at any place.  
Shaft-measured at the back when it is not worn 110 mm - 140 mm.  
The upper edge of the shoe has to be at an angle between 90° and 120° to the back shaft edge.  
A reinforcement of the shoe on the outside of the instep and within the outside area of the ankle is necessary.  
The zipper has to be visible at the front and should not be covered.  
Any kind of taping of the racing shoe is prohibited (except on damaged areas; however, this must be approved by the technical delegate).  
Any stretching devices at, in and outside of the shoe body are prohibited.  
This is also valid for any attachments (for example, bandages, tapes, bindings and similar) for the overall area of the lower leg and foot.  
However, an injured part can be protected by a bandage.  
The necessity and application of the bandage are to be checked by the race physician and/or the technical delegate prior to the begin of the race.  
The racing shoes have to be freely purchasable from the respective manufacturers for all NFs.  
Measurement of racing shoes (refer to Sketch 9).

Approval of a new racing shoe:

New models must be inspected by the chairman of the Technical Commission and two Commission members selected by him and must be approved with the following conditions:

- ♦ New models must be in accordance with the rule in § 5 Section 2.4.
- ♦ One pair of racing shoes may not exceed the price of 150 EURO.  
The inflation rate can be added.
- ♦ Inspected and approved models will be left as sample in the FIL office with a production guarantee.
- ♦ Racing shoes must be manufactured in at least three sizes (37 to 45 European sizes).
- ♦ All the racing shoes used during competitions must be identical in form and material (not color) with the original shoes stored in the FIL office.

Time Frame:

A new model must be approved by July 15<sup>th</sup> by the Chairman and two members of the Technical Commission.

Until August 1<sup>st</sup>, all National Federations must be informed in writing by the FIL office on the new approved racing shoes.

Each National Federation is responsible for ordering the new models, but they can also be ordered through the FIL office.

When the order is made on time (August 31<sup>st</sup>), the new models must be available within two months.

## 2.5 Race Suit

It is mandatory to wear a race suit.

For racing suits, only textile fabrics may be used, the exterior surface of which must not be plasticized or otherwise sealed.

It has to be possible for each National Federation to buy the racing suit material or finished racing suits from all the respective manufacturers.

The race suit has to end by the middle of the foot.

If the race suit is fastened up over the heel, then the heel has to be a part of the suit.

If the race suit ends in the ankle-part, it must have a strap (refer to Sketch 8).

It is forbidden to tape the race suit to the foot or with the socks.

Bootie covers are forbidden.

Sketch 7

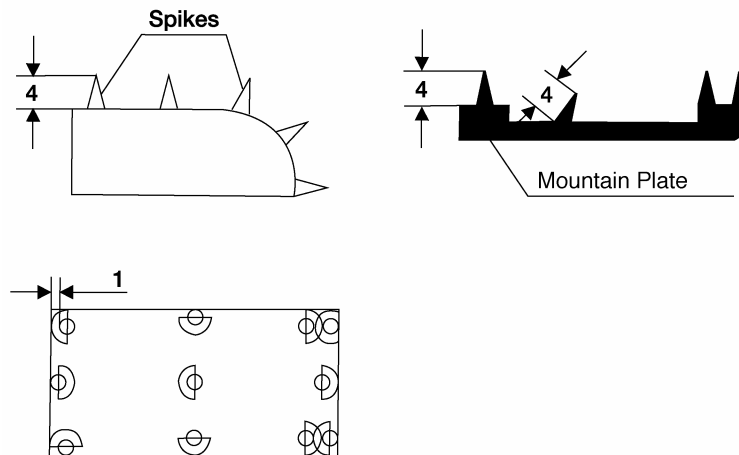

Sketch 8

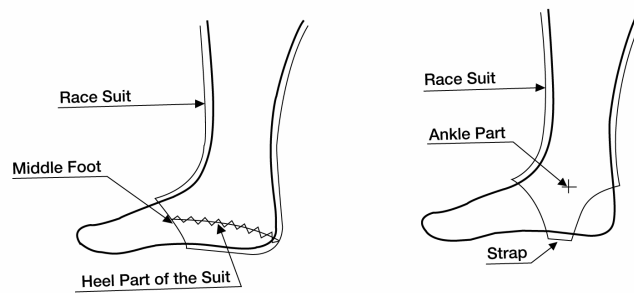

Sketch 9

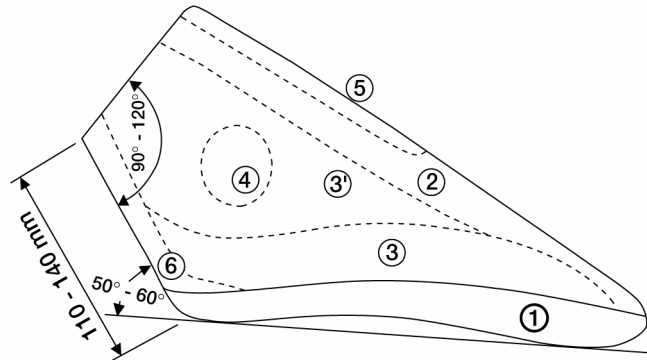

- 1 = The thickness of the sole may not exceed 2 cm.
- 2 = Body of the shoe must comply with the measurements indicated on the sketch.
- 3 = Outer side of foot reinforcement starts at least 3.5 cm after the point of the toe and can be attached to or combined with #6.  
Side height at least 3 cm covering 3/4 of the shoe length starting from the back.
- 3' = Optimal reinforcement of outer side of foot, like #3, can include #4.  
If you do this, #4 is unnecessary.  
3 and 3' can be attached inside or outside of the shoe surface.
- 4 = Reinforced outer anklebone must have a minimum diameter of 35 mm.  
Can be attached inside or outside of the shoe surface.
- 5 = Zipper, minimum length 10 cm.
- 6 = Reinforced heel and backside of shaft goes from the sole to the upper end of the shaft.  
Side covering minimum 1 cm to each side, which can be extended at the joint to the sole. See also #3.

## 2.6 **Start Numbers**

During FIL competitions, bibs are to be used for start numbers.

The start number has to appear on the chest and on the back.

The Executive Board and/or the event organizer can stipulate a second start number (for example: sticker).

Start number bib must be elastic, sleeveless, and adhere closely to the upper body.

They must not be changed.

Taping of the starting bibs at the bottom edge is only allowed to a maximum width of 6 cm.

Tucking in the start number bibs at the sides is only permitted if by doing so neither the number nor the inscriptions are affected.

It is forbidden to bind the shoulder straps together at the back.

With doubles, both athletes have to wear a start number bib.

- ♦ For Junior World Cups and other International Races for Junior and Youth classes, the event organizer may also use start number stickers if the quantity of bibs or the sizes are not available. This is not applicable to the Junior World Championships.

**1. General Regulations**

During official training of the competition and race runs of any FIL competition, the following must be available:

- a) A race physician with knowledge of emergency care.  
During official training, the presence of a race physician may only be dismissed according to 1.1a when a time frame for the emergency aid has been legally determined for the particular nation hosting an event and when its compliance is guaranteed.
- b) A minimum of one ambulance with one paramedic / ambulance officer.  
The ambulance must also be equipped with appropriate resuscitation equipment and be suitable/ capable of accessing all roads around and along the track and which is placed in such a way that, in accordance with the local conditions, a fast pick up of the ill and injured athlete is possible from all areas of the track.
- c) A room exclusively used for first-aid treatment which is marked as such.

Should the race physician and/or the ambulance be medically required, the race and official training must be interrupted until their services according to the above-mentioned regulations are again guaranteed.

**2. Responsibilities**

The race physician and/or the ambulance crew are responsible for the primary care of injuries and illnesses of the athletes.

The race doctor has to certify in writing to the race director when there is a specific risk to life or health by the participation of an athlete as a result of an injury or illness or for any other medical reason (§ 4 Point 1.1.5).

**3. Evacuation of injured athletes**

The event organizers must guarantee that injured persons can be transported away from any point along the entire length of the track without obstruction or difficulties.



**1. Applicability, Measuring Procedure**

**1.1 Applicability**

All these regulations are valid during FIL competitions as well as for media and PR activities and are applicable to athletes and officials.

**1.2 Measuring Procedure**

The size of a commercial marking or trademark is the surface within a line following the actual surrounding of the integrated marking.

If the trademark is integrated within an area of different color, the total area of the different color is to be measured.

The correctness of the measuring of the size of the trademark will be under the responsibility of the National Federations.

At FIL competitions, the race director, technical delegates and jury have the right to carry out control measurements at any time.

**2. Race Clothing**

Articles of clothing may carry manufacturers' identifications and/or trademarks of other sponsors.

The total surface of the trademarks together on the clothing (except head coverings, gloves and shoes) of one person shall not exceed 350 sq cm.

The complete surface can be divided into eight parts at the most.

The complete surface of a single part may not exceed 100 sq cm.

Trademarks of the same sponsor may not appear one above the other or one beside the other.

The National Federations may decide the placing of the trademarks.

The markings on the clothing will be measured when the clothing is not worn.

The respective National Federation is responsible for maintaining the advertising regulations.

The use of a manufacturer's specific graphic design - even though this design may also be registered - will not be counted as advertising spaces.

**3. Safety Helmet**

Athletes' safety helmets may display two (2) trademarks of the manufacturer with a maximum size of 15 sq cm, one each side, placed over the ears.

The advertising surface on the front of helmets may only be used by the FIL (60 sq cm).

It is permitted to wear on the helmet a national emblem (max. 30 sq cm) and also the name of the athlete (maximum twice, height of the writing maximum each 15 mm) at the back of the helmet without obstructing the official FIL advertising.

**4. Goggles/Visor**

Goggle and visor straps shall correspond to products to be purchased freely by the public and may carry two trademarks, not larger than 15 sq cm each.

The width of a goggle's and visor's strap shall not measure more than 4 cm.

In the case of double straps, only one strap may carry the trademark.

**5. Caps, Headbands and other Headgear**

Cap, headband and other headgear may each have a maximum of three (3) trademarks of the manufacturer and/or other sponsors, with a total surface of 90 sq cm maximum.

**6. Start Numbers**

Advertising inscriptions on start numbers are permitted.  
The advertising surface must be smaller than the section bearing the start number.  
During FIL Championships and World Cups of the General Class, the start number bibs provided by the FIL sponsor have to be worn during the official training.

**7. Racing Shoe**

Racing shoes may only show one manufacturer's trademark of 15 sq cm in size on each shoe.  
The trademarks can be divided in two parts.

**8. Gloves**

Gloves may only show one manufacturer's trademark on each glove.  
The marking can be divided into two parts.  
The total surface of the commercial marking per glove is limited to 15 sq cm.

**9. Racing Sled**

On the entire sled, in addition to the manufacturer's trademark, a maximum of five commercial markings may be displayed; maximum of two trademarks on the bottom of the sled.  
The size of the advertising surface on the bottom of the sled may not exceed 900 sq cm.

**10. Athlete**

Advertising with athletes is only allowed with permission of the National Federation responsible.  
Name, title and picture from the athletes can only be used once for each advertisement.

**11. Forbidden Advertising**

- ◆ Any kind of advertising with alcohol, tobacco, and drugs.
- ◆ Any religious or racial discrimination.

## **§ 8 Training, Weigh-in, Individual Supplemental Weights**

### **1. International Training Courses**

- 1.1 The NF that is holding a FIL Championship must provide an international training week before the staging of the championship in the respective season.  
At least 7 training days with a minimum of 4 training runs daily have to be offered to all interested National Federations.  
Should the organizers not follow this requirement, the Executive Board can reject the next application for an event.
- 1.2 Organisers hosting a FIL World Cup or Junior World Cup must make available three (3) days of paid training (five (5) days for juniors) to all teams prior to the event in that season.  
These days must be scheduled during the pre-season / preparation period and cannot be scheduled during the normal event paid training and official training schedule immediately prior to the event.  
A minimum of four (4) training runs each day must be offered.
- 1.3 The execution of international training sessions is strictly a matter of the National Federation (with exception of the OWS).  
The terms of these training sessions are to be set up by mutual agreement and according to individual competence.

### **2. Paid Training**

- 2.1 Two days before the beginning of official training, organizers of FIL competitions/championships and Junior World Cups are obligated to offer paid training.  
The track must be prepared before each group's training.  
Paid training is to be coordinated and controlled by the sport coordinator/technical delegate.  
National Federations have to register for the paid training one week prior to the beginning of that training.  
Junior World Cup:  
On both days before official training, at least one training session per day with at least three runs per training session must be offered.
- 2.2 If it is known in advance that there is not enough time for this paid training (as in the case of the "Drei-Bahnen-Tournee") then the organizers of the FIL competition must provide a minimum of 3 training days.  
This training must take place prior to the competition during a week when there is no World Cup or championship race scheduled.

### **3. Official Training**

- 3.1 **Systematic Training**
  - 3.1.1 A training run on a shortened course (systematic training) has to be offered for singles and doubles.
  - 3.1.2 If an athlete / doubles team does not take a systematic training run, he or she will be removed from that training run without substitution.
  - 3.1.3 If the event organizer provides more than 3 training runs of paid training, there is no obligation to provide systematic training.

- 3.2 Official Training Runs**
- 3.2.1 For FIL competitions, the organizers must hold free of charge at least five (5) training runs for singles and five (5) training runs for doubles.  
These training runs should include one (1) night run if there is to be a night run in the competition.  
These runs are to be timed and are to be conducted on the entire length of the course.
- 3.2.2 The doubles training is to be as follows:
- ♦ one systematic run as singles only if no paid training has previously taken place (at least 4 training runs)
  - ♦ two training runs as singles only if no paid training has previously taken place (at least 2 training runs)
  - ♦ one systematic run as doubles
- 3.2.3 During Junior World Cups and Junior World Championships, seven (7) official training runs have to be provided.
- 3.2.4 The start order for the NFs for training will be drawn at the first team captain's meeting.  
Before the draw, it will be determined by the race director which nation in the drawn start order will begin the actual training run.
- 3.2.5 Two full days will be made available for official training by the organizers.  
There are no exceptions.
- 3.2.6 Reduction of the number of training runs  
If conditions prevail which make it impossible for the competitors to complete their stipulated training runs, i.e. warm wind, snowfall, etc., the race director in discussion with the technical delegates can interrupt training and set up a new training time.  
Regarding the number and completion of training runs, the race director will make a decision after conferring with the technical delegates.
- 3.2.7 Only the competitors eligible to participate in the respective competition may take part in the training (§ 3 Point 8).
- 3.2.8 Doubles athletes may start from the men's or doubles start in singles training.
- 3.2.9 All unauthorized training by competitors on the track other than the designated training times is forbidden.
- 3.2.10 In substantiated cases, with approval of the jury, the race director must allow competitors who have arrived late due to no fault of their own, to complete the minimum number of training runs if time allows them to do so.
- 3.2.11 In conjunction with the technical delegate, the race director is empowered to add additional official training runs.
- 3.2.12 During competitions that are held within a shorter period of time, the technical delegate in agreement with the race director is making the arrangements for training.  
It is to guarantee here that all National Federations have the same conditions.
- 3.2.13 If the competition's planning results in a break of two or more days for athletes, an additional training run must be made available to them.
- 3.3 Rules for World Cup training**
- 3.3.1. Number of training runs
- ♦ At the first World Cup of a season, all athletes are offered an equal number of training runs (at least 6 runs).
  - ♦ In addition to these 6 training runs, newcomers to a track will receive an extra run.
  - ♦ All participants in the preceding World Cup 32 men, 24 women and 16 doubles will receive 6 training runs on two or three training days at the next World Cup.
  - ♦ If athletes according to the ranking specified above fail to appear at training, other athletes will not move up.
  - ♦ One day before World Cup training, all other registered athletes will receive an additional training session with 3 training runs for a total of 9 runs.
  - ♦ Systematic training can be held as part of the 6 or 9 runs offered.

- 3.3.2 **Misceallaneous**
- ◆ The NFs must register with event organizers using the FIL online registration tool.
  - ◆ The training is conducted in groups of approximately 23 to 28 participants.
  - ◆ Within groups, each NF or training partnership will train successionaly with the start order men – women – doubles.
  - ◆ The track must be prepared before each group (under the responsibility of the technical delegate with chief of track).
  - ◆ Training is scheduled and coordinated by the FIL sport coordinator.
  - ◆ The start order for training is determined by the first team captains' meeting.
  - ◆ If athletes should compete in both disciplines – men and doubles – the team captain must nominate the second training of these athletes in another group.
  - ◆ Should athletes have a break of two days in the planning between the last training run and the first race run, an additional training run must be made available to them.
  - ◆ Travel days are allowed for and fixed in the annual schedule.
  - ◆ Event organizers must offer 5 training run per registered sled free of charge.  
All other runs are offered against payment.
- 3.4 In paid training as well as in official training by FIL Championships and World Cup races, men, women and doubles of a country or of a training partnership must train within their groups (does not apply to JWC).
- 3.5 **Timing**  
When the respective start level is reached, the times are to be presented in writing with a start time and three intermediate times.
- 4. Weigh-In**
- 4.1 The weigh-in (men with shorts and women with shirts, shorts and underwear) takes place under the direction of the judge responsible for the weigh-in before the draw.  
Weigh-in of women should be conducted by a female judge.  
The location and time of the weigh-in are to be announced at the first Team Captain's meeting.  
Upon confirmation of the events schedule, the FIL Executive Board, based on the proposal of the Technical Commission, will determine the events which will do a weigh-in of the body weight. (2 - 3 times per season).  
For new athletes or for athletes with weight changes, control weigh-in could be done at each competition.
- ◆ At the weigh-in, athletes competing in doubles event must notify the judges on who will be stepping on the scale with the sled during the competition.
- 4.2 A jury member or technical delegate must be present.
- 4.3 At least one heated room is to be provided by the organizers for the aforementioned weigh-in procedure.
- 4.4 At the draw, all participating National Federations receive a list of their athletes from the organizers on which the following weight information is noted: name, body weight, additional weight, weight of race clothing and total weight permitted for the race.

**5. Individual Supplemental Weights**

- 5.1 Additional weights may be carried in singles' competitions for women, men, junior women and junior men, youth A women and men as well as in doubles, General Class and Junior Class.
- 5.1.1 The maximum amount of additional weight permitted is as follows:
- ◆ Women, Junior Women, Youth A Men 10 kg
  - ◆ Men, Junior Men 13 kg
  - ◆ Youth A Women 8 kg
  - ◆ Doubles (General Class and Junior Class) 10 kg
- 5.1.2 Women, junior women and youth A men may use additional weight amounting to 75% of the difference between body weight and a base weight of 75 kg.
- 5.1.3 Men and junior men may use additional weight amounting to 75% of the difference between body weight and a base weight of 90 kg.
- 5.1.4 Youth A women may use additional weight amounting to 50% of the difference between body weight and a base weight of 70 kg.
- 5.1.5 Doubles athletes in General Class and in Junior Class may use additional weight amounting to 50% of the difference between body weight and a base weight of 90 kg.  
Additional weight is not allowed if the body weight of the front person and back person together exceeds 180 kg.  
If one of the partners weighs more than 90 kg, the weight exceeding the 90 kg mark will be added to the lighter partner.  
If there should still be a difference between the partners weight and the 90 kg mark, the difference can be compensated according to the weight table.
- 5.1.6 The additional weight must be worn by each competitor individually.
- 5.2 The weight of the race clothing may amount to 4 kg and may be compensated for in all disciplines.
- 5.3 Under no circumstances may additional weight be attached to the sled.  
Additional weight is to be carried on the body and must not be able to shift freely.  
It should be attached and distributed in such a manner that bruises or other injuries will not occur.  
Additional weight, including fixings, may not exceed a maximum thickness of 20 mm except on the back of the competitor where it can be 30 mm thick in an area which is 25 cm wide and centered on the axis of the body.

## **§ 9 Race Preparation, Entries, Entry Fee, Draw**

### **1. Entries**

Each NF is to submit written entries for its competitors to the organizers by the deadline appearing in the invitation to the race.

### **2. Entry Fee**

Entry fees for all athletes must be paid to the official designated by the NF prior to the start of the draw who then issues a receipt.

Entry fees remain the property of the sponsoring NF.

For all FIL competitions, the amount of the entry fee for each competitor in each discipline will be determined in Euro by the FIL Executive Board.

Entry fees paid for competitors will not be refunded.

### **3. Draw**

3.1 Time and location of the draw are determined in the invitation to the competition.

3.2 The race director is the chairperson of the draw.

The draw follows the close of the training.

The draw of name and/or NFs is taking place after the announcement of the number.

The draw of number after the announcing of the name is allowed if required due to the creation of a computerized starting list.

3.3 During the draw, the jury must be present.

#### **3.4 FIL Championships in General Class**

Only the start order for the Group A will be an open draw.

The rest of the start order will result from § 3 Point 6.1.

#### **3.5 World Cup**

Only the start order for the Group A will be an open draw.

The rest of the start order will result from the placement of the qualification (§ 3 Point 6.2).

#### **3.6 Junior World Cup / Junior World Championships**

The seeded group A will be drawn by name.

There is no draw for the group B.

The start order result from the overall Junior World Cup ranking by NF (§ 3 Point 5.4).

A necessary draw for athletes/NFs with same points will be done by the jury.

The remaining group will be drawn by National Federation.

Following the draw, the team captains determine which starting number the respective athletes of the group B and the remaining group will have.

- ♦ For the purposes of competitions within Youth A, the entire field will be considered as the rest of the group. This allows the draw to take place by nation with each team captain allowed to decide which starting number its respective athletes will have.

3.7 For the doubles, the names of the team must be known before the draw.

3.8 Names entered for the doubles competition are binding for the duration of the discipline and may not be changed during the race.

- 3.9 During the draw, the times of the start order for the competition have to be announced.
- 3.10 The outcome of the draw (start list) and start order are to be immediately announced publicly. A copy of the start list is to be given to each team captain.
- 3.11 The exchange of start numbers is not permitted.



**1. Start**

**1.1 Start Rules**

In all disciplines, starting from a start ramp is required.

The start times and start order for the athletes are to be clearly displayed at the start and at the finish.

The athletes are responsible for informing themselves promptly of the order and their respective start times.

During the OWS, FIL Championships and World Cup races, 1-3 forerunners have to start per race run.

During Junior World Cup races, forerunners should also be available.

**1.2 Call to Start**

The beginning of each heat must be announced over the loudspeaker system along the track 15, 10, and 5 minutes prior to the first starter.

The call to the start area follows the checking of the sled and athlete in the start area.

The athlete must go to the start area within two (2) minutes of being called.

Only one (1) person is permitted to assist a competitor in the start ramp area.

**1.3 Command to Start**

The signal to start has to be carried out acoustically and optically by a time display which is clearly visible to the athlete.

At start installations with electronic signals, a red/green light and start clock are obligatory.

The track is closed to all athletes when the light is red.

The athlete at the start may only start if the green light is visible.

The start must take place within thirty (30) seconds after the "Track is Clear" notice for singles and within 45 seconds after the "Track is Clear" notice for doubles.

The start is valid if the athlete has left the start handles within this time with a push and has put the sled in motion.

A flying start is not allowed.

When an interruption occurs during a competition (with the exception of a determined sweeping interval in case of snowfall), the starter must give the next athlete two (2) minutes preparation time before the signal "Track is Clear" is given.

**1.4 Start Intervals**

Only one sled may be on the run at any one time.

The starter may allow the athlete to start only if the "Track is Clear" statement has been relayed to the start leader from the finish.

**1.5 Start Assistance**

Assistance by others to accelerate is forbidden.

**2. Controls at the Start**

At the start, the following checks will be made:

- ♦ Temperature of the blades - will also be checked on forerunners, he/she may not start if blades are too warm.
- ♦ Fastening of the start number.
- ♦ Weight controls of the athlete and sled  
(During junior / youth races, weight controls of sled and athlete can also be done at the finish for organizational reasons).
- ♦ The empty spaces / spaces to be measured between runner and blade

The results of the examinations at the start are to be noted in the official records.

- 2.1 **Weight controls of athlete and sled**
- 2.1.1 All athletes together with their sleds will be weighed at the start before each run (in doubles, only one athlete together with sled (§ 8 Point 4.1)).  
The sum of the body weight, weight of the race clothing and additional weight is not to be exceeded. The results are to be entered in a list.
- 2.1.2 The weighing procedure at the start will be checked by a technical delegate.
- 2.1.3 The scale must reflect incremental units of 100 g.
- 2.1.4 A gauged scale must be installed for the pre-competition weigh-in for the athletes under supervision of a judge both at the start (women's or men's start) and at the finish.  
These scales must be placed at the disposal of the athletes 1 ½ hours before the beginning of the race.  
Gauged control weights (5 x 20 kg) and gauge records must be available for weigh-in.  
At the Winter Olympic Games and FIL Championships, scales must be set up under the same prerequisites in both start areas.
- 2.2 **Measurement of the temperature of the blades**
- 2.2.1 An official temperature check of the blades, using approved equipment, is to be conducted by the official involved with blade measurement between the call to start and start preparation.  
Results are to be entered in the official records in half degrees.
- 2.2.2 Each blade is to be tested at each point where the runners are attached to the bridges.  
(Total: twice on each blade).
- 2.2.3 At the start, a control blade 50 cm long, corresponding to the profile of a blade, is to be set up as permanent equipment attached in a location sheltered from the sun, and is to be used as a basis for temperature measurement.  
The temperature of the control blade is to be taken 30 minutes before the start and is to be repeated every 15 minutes from that time.  
The results of these temperature checks are to be posted in half degrees on a notice board that is visible to everyone.  
The temperature of the blades on each athlete's sled may not be greater than 5°C above the control temperature.  
The control temperature is established from the control blade located at a height of 1/2 to 1 meter from the ground.  
Should the temperature of the control blade fall below -10°C, the blade temperature measurement may be as warm as -5°C.
- 2.2.4 At the start, two (2) measuring gauges are to be made available for temperature measurement.  
One gauge is used by the judge for official measurement; one gauge is available for use by participants for (personal) measurement checks.  
Official and control measurements are to be recognized as such without any doubt.  
The second control measurement gauge may only be used by a judge expressly assigned to it.  
One is not permitted to give this device to coaches or other persons for control checks.  
Both pieces of equipment are to be marked differently from one another.  
The official measurement will be conducted in the start area.  
No more than two sleds may be brought to the start area at any one time for an official measurement.  
In the start area, each sled will only be measured once.
- 2.2.5 After the beginning of the official measurement, the sled must not be removed from the designated start area. This also pertains if there is a delay in starting.
- 2.2.6 After examination in the start area, the sled must neither be exchanged nor the blades warmed.
- 2.2.7 Every sled preparation to improve the gliding process is not allowed after the official controls at the start.
- 2.3 **Control of the start number fastening**  
The start number fastening is to be checked visually.
- 2.4 **Start under protest**  
A start under protest has to be granted.

### 3. **Finish**

- 3.1 The finish, and with it the end of the competition run, is defined by the light barrier.
- 3.2 In the finish area, the technical delegate must arrange a zone where the athlete must be able to leave the track without any help.  
The athlete must go to the scale alone.  
An escort in this zone is not allowed.  
This is valid for the OWS, FIL Championships and World Cups in the General Class.
- 3.3 Under the responsibility of the organizers of Championships and World Cups, a time display has to be installed at the end of the outrun where the times of each run and the current ranking of the athlete will be shown sufficiently long enough to be seen by the athletes.

### 4. **Controls at the Finish**

- 4.1 The control weighing of the additional weight, sled and race clothing, the check of the temperature of the runners as well as measurement of the sled and seat (pod) of the drawn athlete at the finish take place in the following order:
- ♦ Singles      First Run      - 6 drawn athletes, 3 of them from group A  
                  Second Run      - no draw
  - ♦ Doubles     First Run      - 3 drawn athletes (one athlete from each doubles team )  
                  Second Run      - no draw
- The draw will be carried out upon the arrival of the athlete at the finish area under the supervision of a jury member or technical delegate.  
The results of the examination at the finish are to be noted in the official records.
- 4.1.1 During the measuring process, the sled must be laying on the table on its own without the support of an official (§ 5 Point 1.9).
- 4.1.2 By the control of the pod, the athlete must lay down on the sled in the sliding position.  
In doubles, the front man must fasten his seat strap (§ 5 Point 1.9).
- 4.2 One of the three lots from the group A will be marked in an additional way.  
After the first run, the sled of the athlete who has drawn this lot will be marked by the technical delegate and controlled after the second run in accordance with § 5 Points 1.11 and 1.12.  
Under supervision of the technical delegate, a member of the team will dismantle a runner from the sled of the drawn athlete and the technical delegate will control the connection of bridges in the runners.  
If in the second run, this athlete uses another sled than in the first run, he or she must also present the marked sled from his or her first run, so that it can be controlled.
- ♦ Regarding junior competitions, the controls according to § 10 Point 4.2. will be carried out at the World Junior Championships and Junior World Cups. Random check will be carried out by the controls in the Youth A.
- During the OWS and FIL Championships, the sled of the first three places in all disciplines will be controlled after the last run.
- 4.3 The checking of racing equipment and sled may take place, point by point, among additional athletes by order of the technical delegate.

### 5. **General Rules**

#### 5.1 **Principle Rule**

During all FIL competitions, the athlete must travel on his/her sled from the start to the finish in a seated or reclined position.  
If an athlete crashes, he/she must always be in contact with the sled. A crash is not grounds for disqualification.

- 5.2 **Passing the finish line**  
If an athlete crashes close to the finish, he/she must pass this finish line in contact with his/her sled. Pushing, paddling or carrying the sled across the finish is not allowed.
- 5.3 **Modification and exchange of the sled**  
The exchange of, or modifications to, the sled during a discipline are permitted in accordance with the rules.
- 5.4 **Workshop**  
A suitable workshop area is to be placed at the disposal of the athletes by the organizers so that necessary work may be completed on their sleds.
- 5.5 **The entire length of the track is to be checked.**  
When the OWS, FIL Championships and World Cup races are staged on tracks with critical wind factors, anemometers must be installed at the exposed areas.  
Decisions for the location are to be made by the Technical Commission of the FIL.  
If wind speeds from more than 20 km/h (5.6 m/sec.) are measured, the technical delegate and the race director decide upon further training and/or racing procedures.
- 5.6 **Track alterations during the execution of a discipline**  
If weather conditions, such as snow, thaw, etc. create unequal conditions for individual athletes during a race, organizers must provide a readily available work crew.  
While the forerunners are starting, the technical delegate determines the intervals of the sweeping as follows:
- ◆ sweeping interval (for example after every third athlete)
  - ◆ sweeping time (for example 1 minute)
  - ◆ if there is a break during a run, the track is swept until the next athlete starts (break time = sweeping time)
  - ◆ during the last run, the distribution of the sweeping intervals starts with the best rank
  - ◆ the race director is responsible for the entire sweeping intervals. The team captains have to be informed.
- Any conscious change of track conditions during a race is forbidden.
- 5.7 **Quality of the track**  
During final training and competition of each discipline (can be one or more runs), the following conditions must be adhered to:
- ◆ Change to the ice profile may no longer be done (only damaged areas can be repaired).
  - ◆ The ice must be prepared at best (racing condition).
  - ◆ The ice temperature must be kept as constant as possible.
  - ◆ There must be sweeping intervals during snow fall.
  - ◆ Sun shades must not be used (only if required).
  - ◆ This arrangement must be determined by the technical delegate and race director.
- 5.8 The decision whether the track is prepared prior to a run will be made by the technical delegate together with the race director.
- 5.9 Competitions may be held in extreme weather conditions with a temperature as low as -25°C.
- 5.10 If a competitor loses any item during a run with the exception of visors or goggles, that athlete will be disqualified.
- 5.11 **Transportation of sleds and athletes**  
Along the track, there must be paths or other facilities which make it possible for the athletes to travel with their sleds from the finish to their respective starts without great difficulty.  
It is necessary to provide adequate opportunities for parking in the start and/or finish areas.

## **6. Timing**

### **6.1 Timing Equipment**

Timing equipment with automatic and printing capabilities is required and must operate with at least one (1) start time, three (3) intermediate times and the finish time with an accuracy of 1,000th of a second.

The official start and finish light barriers have to be marked during training and competition in color across the entire bottom and sides of the track.

Additional light barriers at the start and finish area have to be covered.

The installation of additional timing equipment is forbidden.

### **6.2 Preparation**

The timing equipment must be tested and be ready for use at least one (1) hour before the beginning of each discipline.

### **6.3 Difficulties**

If a problem occurs with the timing equipment, the timer responsible must immediately inform the race director; the race director may interrupt the race as long as it takes to guarantee proper timing. The athletes who were affected by the timing failure must repeat their runs at the latest within 30 minutes. The race director will decide on the exact starting time.

This also applies during training.

### **6.4 Breakdown of timing equipment**

If there is a more lengthy breakdown of the electronic timing equipment during a heat, the heat may be annulled by the race director with the consent of the technical delegates.

### **6.5 Finish House**

Team officials and competitors are not permitted in the area in which the recording of time is performed during the duration of the competition.

## **7. Results**

7.1 The official results are the total sum of the times recorded by the athletes in each individual heat.

7.2 If two or more athletes record the same time for a run, they are awarded the same place.

7.3 The first and family name (last name) and start number of athletes who dropped out or who were disqualified are to be entered in the results lists with the times achieved up to that point.

Under "dropped out ", all applicable athletes are classified as:

- ◆ Did not start (DNS) e.g. sickness, injury
- ◆ Did not finish (DNF) e.g. did not finish due to a crash.

7.4 The official results list is to be signed by the race director and the chairperson of the jury.

The names of the jury members and of the technical delegates are to be listed.

The full names of all participants are to be entered on the results list.

7.5 At the end of the competition, the official results lists or CD are to be distributed to each National Federation participating in the competition.

One original copy must be sent to the FIL office immediately after the competition.

### **7.6 Results and timing lists as evidence**

The official times for each athlete are to be immediately recorded in writing.

All documentary evidence is to be used as a basis for checking and for possible protests.

All documentary evidence is to be kept by the organizer for a period of one year after the end of a competition.

**1. Reason for a Protest**

If an athlete believes himself/herself to be at a disadvantage due to factors which have occurred during official training, a race run or for another reason during a competition, the team captain has the right to protest.

A flash does not provide a reason for protest.

The jury decides on all protests.

**2. Procedure**

2.1 Protests must be made in writing and must be signed by the team captain or the team captain's representative.

2.2 The protest must be given to the chairperson of the jury.

2.3 A protest fee of 50 Euros is to be paid when the protest is submitted.

2.4 The written protest must be submitted within 10 minutes of the completion of the official training session or competition heat or the cause for the protest in question.

**3. Settlement**

3.1 Concerning a protest, the jury must meet within one (1) hour of the submission of the protest. If the reason for the protest is first known after the ten minutes (noted in Point 2.4), the jury must deal with the protest and observe the final deadline for submission of the protest which is the conclusion of the competition (awards ceremony).

3.2 The jury may call in all persons and items connected with the protest on the spot to help clarify the circumstances.

In the case of a protest, the jury has to decide whether pieces of evidence (for example, films, pictures, video records, etc.) may be presented.

However, this material is only used to help in making a decision.

3.3 The decision of the jury in all protests is final. It may only be appealed against in accordance with the FIL Law and Procedure Regulations.

3.4 The protest fee is returned in its entirety if the protest is decided in favor of the protesting party.

3.5 If the protest is denied, the protest fee is forfeited and is given to the organizers of the event.

3.6 If events or occurrences in violation of the IRO are discovered after the conclusion of the competition, the FIL Executive Board will make the decision in these cases.

**1. Titles for World Championships**

The invitation to the race notes the titles to be awarded at the FIL Championships. These are to be awarded to the winners in the following disciplines:

- 1.1 **Men's Singles with the title:**  
"World Champion in Men's Singles"
- 1.2 **Women's Singles with the title:**  
"World Champion in Women's Singles"
- 1.3 **Doubles with the title:**  
"World Champion in Doubles"  
Both competitors receive the same titles and same honors.
- 1.4 **Team Competition with the title:**  
"Team World Champion"
- 1.5 The same titles and honors are used for the Junior World Championships.

**2. Titles for Continental Championships**

The titles for Continental Championships are to be bestowed with the same name as the corresponding competition.

**3. Awarding of titles in case of a reduction of runs**

If the number of runs in a discipline is reduced, titles are only awarded if all athletes participate in at least one run.

**4. Certificates**

4.1 The certificate is an individual and written confirmation of participation in a championship. The following must be clearly noted on the certificate:

- ◆ Name of the sponsoring NF
- ◆ Type of championship and the discipline in which the competitor participated
- ◆ Name of the athlete
- ◆ Level reached by the competitor in the final rankings
- ◆ Signatures of the FIL representative, chairperson of the jury and race director
- ◆ Location and dates of the event

4.2 Each competitor and official participating in a championship must receive a certificate.

**5. Medals**

5.1 For FIL Championships, World Cups and Nations Cups, medals are awarded for places 1 to 3.

5.2 The medals are provided as follows:

- ◆ By the FIL: World Championships, Junior World Championships and Overall World Cup in General Class and Junior Class.
- ◆ By the organizers: Continental Championships, individual World Cup, Junior World Cup and Nations Cup.

6. **Pins for Competitors and Officials**

It is the obligation of the NF staging FIL Championships to give pins or badges as gifts at no cost to the athletes and officials.

7. **Gifts of Honor and Mementos**

The organizers are permitted to give participants in FIL Championships and FIL competitions gifts of honor and mementos.

8. **Awards Ceremony and Conclusion of the Event**

8.1 **Procedure**

The organizers must hold the awards ceremony for the champions as well as for the second and third place finishers in each discipline immediately after the competition in the finish area as follows:

- ♦ At the awards ceremony of all FIL competitions, flags of the National Federations of the champions and the second and third place finishers must be raised. During the ceremony, the champion's national anthem must be played.
- ♦ If there are less than three ranked athletes in one discipline, this awards ceremony will not be staged.
- ♦ The staging of the official awards ceremony together with the flower ceremony is allowed.
- ♦ In the event of a tie for first place, the anthems of both competitors will be played in alphabetical order of family names.
- ♦ In the case of a tie in doubles, the family name of the front man is used.
- ♦ In the event of a tie, both flags will be raised.
- ♦ The same procedure may take place at all international competitions.
- ♦ The medals are presented to the top three finishers by the FIL representative. By the representative's absence, the chairperson of the jury awards them in a festive ceremony.

8.2 **Awards Ceremony for Overall World Cup**

The champions as well as the athletes placed second and third in the overall World Cup in the men's, women's and doubles' disciplines receive World Cup trophies provided by the FIL. The top three ranked athletes in each discipline, as per total scoring, receive medals in gold, silver, and bronze.

The World Cup trophies and medals will be awarded at the awards ceremony of the last competition (World Cup final).

8.3 **Awards Ceremony for the Overall Junior World Cup**

The overall champions of the Junior World Cups receive trophies provided by the FIL.

The top three ranked athletes in each discipline, as per total scoring, receive medals in gold, silver, and bronze.

The trophies and medals will be awarded at the respective last competition (final competition).

8.4 At the conclusion of an awards ceremony at FIL Championships, the FIL President or representative presents the FIL flag in a ceremonious manner to the representative of the NF which will stage the next FIL Championships.



### **§ 13 Concluding Regulations**

1. The IRO is available in German and English.  
In case of unclarity or contradictions, the German text is binding.  
All event organizers are required to provide a translator at all team captains meetings for German and English.  
Furthermore, translator(s) must be on-site during the race day to assist with translation in the event an emergency, protest, or other matter surfaces.
2. Resolutions regarding amendments and additions to the IRO can only be made by an ordinary Congress and require a simple majority as long as the priority regulations of the FIL statutes do not state otherwise.  
Urgency motions to change the IRO are only permitted in adherence to the FIL statutes.
3. In substantiated cases for exceptions, changes in the IRO may be decided by the FIL Executive Board upon proposal by the appropriate expert commission.  
They will be presented for ratification at the next FIL Congress.  
The same is valid in case of controversial interpretations, contradictions and omissions in the regulations of the IRO.
4. Changes and additions to the IRO become valid with the beginning of the following sport year on July 1st.
5. This edition of the IRO becomes valid from July 1, 2006 onwards.  
At the same time, the former regulations of the IRO become invalid.

## Supplement 1

### Regulation for Artificial Luge Tracks

#### 1. General

All championships and competitions awarded by the FIL are staged on tracks which are recognized by the FIL and which are officially commissioned.

#### 2. Definition

2.1 Artificial luge tracks are luge tracks which have been specially constructed for the sport of luge by means of specific construction measures.

A difference is made between artificial luge tracks with or without refrigeration system.

2.2 Combined bobsleigh and luge tracks are tracks which have been specially constructed for the sport of bobsleigh and luge by means of specific construction measures.

A difference is made between tracks with or without refrigeration system.

2.3 Shortened tracks are artificial luge tracks with or without a refrigeration system with a minimum length of 400 m.

They are suitable for international competitions.

#### 3. Regulations for the Construction of Tracks

##### 3.1 **Length of the track**

The minimum length of the track between start and finish lines must be at least 1,000 m for men's singles and at least 800 m for women's singles, doubles and juniors.

The maximum length between start and finish lines may not be more than 1,300 m for men's singles and 1,050 m for women, doubles and juniors.

By the staging of FIL competitions, the Executive Board can make exception rules with regards to the maximum length between start and finish line.

During the staging of FIL competitions, the track may be shortened upon a decision of the jury should special circumstances require the adjustment.

##### 3.2 **Finish outrun**

The gradient of the outrun must not exceed 20% and must give the athletes the possibility for an exit along one side.

The length must be calculated so that a sled, without braking, will not exceed 40 km per hour at the end of the outrun.

The sled must be able to travel further unhindered.

Should a gentle angle or a curve be necessary in the outrun area, this must not be considered as a braking area.

##### 3.3 **Shortened tracks**

###### 3.3.1 Minimum length 400 m

Track components: 1 left curve, 1 right curve, 1 labyrinth, 1 straightaway.

3.3.2 If one wishes to build a shortened track into full length according to section 3.1, the shortened section should be the upper part of the final track.

The top speeds on a shortened track must not exceed 80 km/h.

- 3.4 **Start facilities**  
For men, women, juniors and doubles events, the track must be equipped with all the necessary starting structures for guaranteeing the normal execution in all disciplines.  
During FIL competitions, it must be possible to close off the starting zone.  
The individual components of the start facility are: a horizontal iced surface on which the sitting position on the sled may be taken by the athlete.  
Length of the horizontal iced surface to the start handles: at least 2000 mm.  
Length of the horizontal iced surface from the start handles to the beginning of the descent: 500 mm (refer to Sketch I).  
Two start handles adjustable in height and width on either side of the start area which may be used by the athletes to increase the speed of their start (refer to Sketch II).  
From the ice to the upper edge of the handles at an equal height: 230 mm - 250 mm.  
Inside distance between the two handles: 700 mm.  
Length of the handle: at least 150 mm.  
Diameter of the handle: 27 mm.  
Upper surface of the handle must be grooved.  
The construction of the start handle should be so solid that it may not be bent upon the athlete's pull off.  
The timing equipment must be constructed no further than 10 m below the start handles.
- 3.5 **Safety regulations**  
The track layout and components such as curves, walls, bridges, tunnels, transportation set-ups, etc. as well as all facilities originally belonging to the track must be provided in such a way, that they meet the internationally recognized safety standards.  
If the safety regulations on a track are neglected so that the participants in FIL competitions are exposed to a typical danger to their health, the track may only be released by the technical delegate for further use if these deficiencies are removed.  
If the steps taken are not sufficient in order to guarantee that the internationally recognized safety standards are followed during a competition, the jury, in accordance with the technical delegates is empowered to shorten the track.
- 3.6 **Commissioning**  
The FIL Executive Board decides on official recognition and approval of an artificial luge track for OWS, FIL Championships and FIL competitions after the following criteria have been fulfilled:
- ◆ Examination of the project documentation.
  - ◆ Inspection during summer construction.
  - ◆ Release of the project through the designers and construction engineers.
  - ◆ Release of the track for the test is done by at least two members of the Track Construction Commission.
  - ◆ The test must be carried out by at least 2 men and 2 women in singles and 2 doubles.
  - ◆ Upon a successful test, the track will be commissioned by the Executive Board of the FIL.
  - ◆ The final commissioning of the entire track facility will be issued according to the criteria in the Book of Requirements.
- The expenses are assumed by the track owner.  
The owners are to receive written information concerning the commissioning of an artificial luge track within one (1) month after a positive resolution by the FIL Executive Board.  
The members of the FIL will be informed of this decision in the next bulletin.  
An official recognition (commissioning) and approval is in general only granted for 10 years.  
After expiration of this time period, the track operator has to apply for an extension.  
Where construction measures have been performed in the meanwhile, the track has to be approved again.  
The commissioning can include requirements.

**Buildings at the track**

- ♦ Two start houses (men's start, women's start) with the following rooms:
  - 1 room for timing with a direct view of the start with frost-free windowpanes
  - 1 large room for use by the teams (for approximately 60 persons)
  - 1 room for press, radio, and television
  - 1 refreshment area, appropriately separated, yet which can be combined with the team's room (for press, officials, athletes, track builders, etc.)
  - toilets for men and women
- ♦ A finish house with the following rooms:
  - 1 room for complete timing
  - 1 room for jury and technical delegates
  - 1 room for information services (press, radio, television)
  - 1 soundproof locked room for the announcer with a direct view of the finish and timing
  - 1 first-aid room
  - toilets for men and women
  - 1 workshop (with necessary equipment)
  - 1 room for dignitaries.
- ♦ Control room directly at the finish outrun
- ♦ Check points along the track have to be built in sufficient numbers, which make it possible to view the entire track (can be omitted if a video system is available with which the track can be sufficiently checked).
- ♦ Stands for honorary guests as well as facilities for press, radio and television above all within the start and finish area.

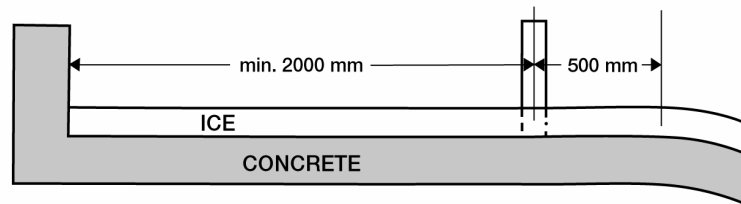
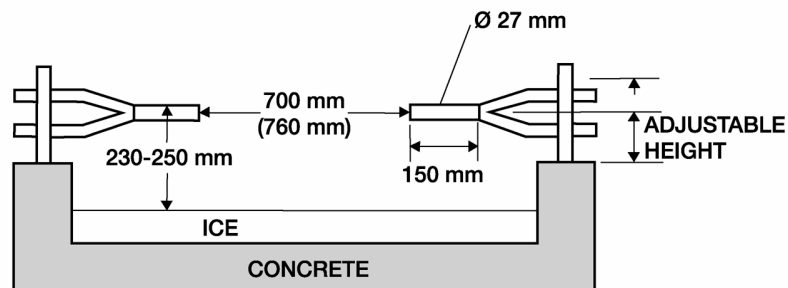
**Sketch I****Sketch II**

## Supplement 2

### Individual Weight Allowances

**Men/ Junior Men:**

Additional Weight Allowance (AW) = 75% of the difference between 90 kg and body weight (BW) (max. 13 kg)

Total Weight Allowance (TW) = BW + AW + 4 kg Race Clothing (RC)

| Body Weight<br>BW in kg | Additional Weight<br>AW in kg | Race Clothing<br>RC in kg | Total Weight<br>TW in kg | Total<br>with Sled |
|-------------------------|-------------------------------|---------------------------|--------------------------|--------------------|
| 72,7                    | 13,0                          | 4,0                       | 89,7                     | 112,7              |
| 72,8                    | 12,9                          | 4,0                       | 89,7                     | 112,7              |
| 72,9                    | 12,8                          | 4,0                       | 89,7                     | 112,7              |
| <b>73,0</b>             | <b>12,8</b>                   | <b>4,0</b>                | <b>89,8</b>              | <b>112,8</b>       |
| 73,1                    | 12,7                          | 4,0                       | 89,8                     | 112,8              |
| 73,2                    | 12,6                          | 4,0                       | 89,8                     | 112,8              |
| 73,3                    | 12,5                          | 4,0                       | 89,8                     | 112,8              |
| 73,4                    | 12,5                          | 4,0                       | 89,9                     | 112,9              |
| 73,5                    | 12,4                          | 4,0                       | 89,9                     | 112,9              |
| 73,6                    | 12,3                          | 4,0                       | 89,9                     | 112,9              |
| 73,7                    | 12,2                          | 4,0                       | 89,9                     | 112,9              |
| 73,8                    | 12,2                          | 4,0                       | 90,0                     | 113,0              |
| 73,9                    | 12,1                          | 4,0                       | 90,0                     | 113,0              |
| <b>74,0</b>             | <b>12,0</b>                   | <b>4,0</b>                | <b>90,0</b>              | <b>113,0</b>       |
| 74,1                    | 11,9                          | 4,0                       | 90,0                     | 113,0              |
| 74,2                    | 11,9                          | 4,0                       | 90,1                     | 113,1              |
| 74,3                    | 11,8                          | 4,0                       | 90,1                     | 113,1              |
| 74,4                    | 11,7                          | 4,0                       | 90,1                     | 113,1              |
| 74,5                    | 11,6                          | 4,0                       | 90,1                     | 113,1              |
| 74,6                    | 11,6                          | 4,0                       | 90,2                     | 113,2              |
| 74,7                    | 11,5                          | 4,0                       | 90,2                     | 113,2              |
| 74,8                    | 11,4                          | 4,0                       | 90,2                     | 113,2              |
| 74,9                    | 11,3                          | 4,0                       | 90,2                     | 113,2              |
| <b>75,0</b>             | <b>11,3</b>                   | <b>4,0</b>                | <b>90,3</b>              | <b>113,3</b>       |
| 75,1                    | 11,2                          | 4,0                       | 90,3                     | 113,3              |
| 75,2                    | 11,1                          | 4,0                       | 90,3                     | 113,3              |
| 75,3                    | 11,0                          | 4,0                       | 90,3                     | 113,3              |
| 75,4                    | 11,0                          | 4,0                       | 90,4                     | 113,4              |
| 75,5                    | 10,9                          | 4,0                       | 90,4                     | 113,4              |
| 75,6                    | 10,8                          | 4,0                       | 90,4                     | 113,4              |
| 75,7                    | 10,7                          | 4,0                       | 90,4                     | 113,4              |
| 75,8                    | 10,7                          | 4,0                       | 90,5                     | 113,5              |
| 75,9                    | 10,6                          | 4,0                       | 90,5                     | 113,5              |
| <b>76,0</b>             | <b>10,5</b>                   | <b>4,0</b>                | <b>90,5</b>              | <b>113,5</b>       |
| 76,1                    | 10,4                          | 4,0                       | 90,5                     | 113,5              |
| 76,2                    | 10,4                          | 4,0                       | 90,6                     | 113,6              |
| 76,3                    | 10,3                          | 4,0                       | 90,6                     | 113,6              |
| 76,4                    | 10,2                          | 4,0                       | 90,6                     | 113,6              |

| <b>Body Weight<br/>BW in kg</b> | <b>Additional Weight<br/>AW in kg</b> | <b>Race Clothing<br/>RC in kg</b> | <b>Total Weight<br/>TW in kg</b> | <b>Total<br/>with Sled</b> |
|---------------------------------|---------------------------------------|-----------------------------------|----------------------------------|----------------------------|
| 76,5                            | 10,1                                  | 4,0                               | 90,6                             | 113,6                      |
| 76,6                            | 10,1                                  | 4,0                               | 90,7                             | 113,7                      |
| 76,7                            | 10,0                                  | 4,0                               | 90,7                             | 113,7                      |
| 76,8                            | 9,9                                   | 4,0                               | 90,7                             | 113,7                      |
| 76,9                            | 9,8                                   | 4,0                               | 90,7                             | 113,7                      |
| <b>77,0</b>                     | <b>9,8</b>                            | <b>4,0</b>                        | <b>90,8</b>                      | <b>113,8</b>               |
| 77,1                            | 9,7                                   | 4,0                               | 90,8                             | 113,8                      |
| 77,2                            | 9,6                                   | 4,0                               | 90,8                             | 113,8                      |
| 77,3                            | 9,5                                   | 4,0                               | 90,8                             | 113,8                      |
| 77,4                            | 9,5                                   | 4,0                               | 90,9                             | 113,9                      |
| 77,5                            | 9,4                                   | 4,0                               | 90,9                             | 113,9                      |
| 77,6                            | 9,3                                   | 4,0                               | 90,9                             | 113,9                      |
| 77,7                            | 9,2                                   | 4,0                               | 90,9                             | 113,9                      |
| 77,8                            | 9,2                                   | 4,0                               | 91,0                             | 114,0                      |
| 77,9                            | 9,1                                   | 4,0                               | 91,0                             | 114,0                      |
| <b>78,0</b>                     | <b>9,0</b>                            | <b>4,0</b>                        | <b>91,0</b>                      | <b>114,0</b>               |
| 78,1                            | 8,9                                   | 4,0                               | 91,0                             | 114,0                      |
| 78,2                            | 8,9                                   | 4,0                               | 91,1                             | 114,1                      |
| 78,3                            | 8,8                                   | 4,0                               | 91,1                             | 114,1                      |
| 78,4                            | 8,7                                   | 4,0                               | 91,1                             | 114,1                      |
| 78,5                            | 8,6                                   | 4,0                               | 91,1                             | 114,1                      |
| 78,6                            | 8,6                                   | 4,0                               | 91,2                             | 114,2                      |
| 78,7                            | 8,5                                   | 4,0                               | 91,2                             | 114,2                      |
| 78,8                            | 8,4                                   | 4,0                               | 91,2                             | 114,2                      |
| 78,9                            | 8,3                                   | 4,0                               | 91,2                             | 114,2                      |
| <b>79,0</b>                     | <b>8,3</b>                            | <b>4,0</b>                        | <b>91,3</b>                      | <b>114,3</b>               |
| 79,1                            | 8,2                                   | 4,0                               | 91,3                             | 114,3                      |
| 79,2                            | 8,1                                   | 4,0                               | 91,3                             | 114,3                      |
| 79,3                            | 8,0                                   | 4,0                               | 91,3                             | 114,3                      |
| 79,4                            | 8,0                                   | 4,0                               | 91,4                             | 114,4                      |
| 79,5                            | 7,9                                   | 4,0                               | 91,4                             | 114,4                      |
| 79,6                            | 7,8                                   | 4,0                               | 91,4                             | 114,4                      |
| 79,7                            | 7,7                                   | 4,0                               | 91,4                             | 114,4                      |
| 79,8                            | 7,7                                   | 4,0                               | 91,5                             | 114,5                      |
| 79,9                            | 7,6                                   | 4,0                               | 91,5                             | 114,5                      |
| <b>80,0</b>                     | <b>7,5</b>                            | <b>4,0</b>                        | <b>91,5</b>                      | <b>114,5</b>               |
| 80,1                            | 7,4                                   | 4,0                               | 91,5                             | 114,5                      |
| 80,2                            | 7,4                                   | 4,0                               | 91,6                             | 114,6                      |
| 80,3                            | 7,3                                   | 4,0                               | 91,6                             | 114,6                      |
| 80,4                            | 7,2                                   | 4,0                               | 91,6                             | 114,6                      |
| 80,5                            | 7,1                                   | 4,0                               | 91,6                             | 114,6                      |
| 80,6                            | 7,1                                   | 4,0                               | 91,7                             | 114,7                      |
| 80,7                            | 7,0                                   | 4,0                               | 91,7                             | 114,7                      |
| 80,8                            | 6,9                                   | 4,0                               | 91,7                             | 114,7                      |
| 80,9                            | 6,8                                   | 4,0                               | 91,7                             | 114,7                      |
| <b>81,0</b>                     | <b>6,8</b>                            | <b>4,0</b>                        | <b>91,8</b>                      | <b>114,8</b>               |

| <b>Body Weight<br/>BW in kg</b> | <b>Additional Weight<br/>AW in kg</b> | <b>Race Clothing<br/>RC in kg</b> | <b>Total Weight<br/>TW in kg</b> | <b>Total<br/>with Sled</b> |
|---------------------------------|---------------------------------------|-----------------------------------|----------------------------------|----------------------------|
| 81,1                            | 6,7                                   | 4,0                               | 91,8                             | 114,8                      |
| 81,2                            | 6,6                                   | 4,0                               | 91,8                             | 114,8                      |
| 81,3                            | 6,5                                   | 4,0                               | 91,8                             | 114,8                      |
| 81,4                            | 6,5                                   | 4,0                               | 91,9                             | 114,9                      |
| 81,5                            | 6,4                                   | 4,0                               | 91,9                             | 114,9                      |
| 81,6                            | 6,3                                   | 4,0                               | 91,9                             | 114,9                      |
| 81,7                            | 6,2                                   | 4,0                               | 91,9                             | 114,9                      |
| 81,8                            | 6,2                                   | 4,0                               | 92,0                             | 115,0                      |
| 81,9                            | 6,1                                   | 4,0                               | 92,0                             | 115,0                      |
| <b>82,0</b>                     | <b>6,0</b>                            | <b>4,0</b>                        | <b>92,0</b>                      | <b>115,0</b>               |
| 82,1                            | 5,9                                   | 4,0                               | 92,0                             | 115,0                      |
| 82,2                            | 5,9                                   | 4,0                               | 92,1                             | 115,1                      |
| 82,3                            | 5,8                                   | 4,0                               | 92,1                             | 115,1                      |
| 82,4                            | 5,7                                   | 4,0                               | 92,1                             | 115,1                      |
| 82,5                            | 5,6                                   | 4,0                               | 92,1                             | 115,1                      |
| 82,6                            | 5,6                                   | 4,0                               | 92,2                             | 115,2                      |
| 82,7                            | 5,5                                   | 4,0                               | 92,2                             | 115,2                      |
| 82,8                            | 5,4                                   | 4,0                               | 92,2                             | 115,2                      |
| 82,9                            | 5,3                                   | 4,0                               | 92,2                             | 115,2                      |
| <b>83,0</b>                     | <b>5,3</b>                            | <b>4,0</b>                        | <b>92,3</b>                      | <b>115,3</b>               |
| 83,1                            | 5,2                                   | 4,0                               | 92,3                             | 115,3                      |
| 83,2                            | 5,1                                   | 4,0                               | 92,3                             | 115,3                      |
| 83,3                            | 5,0                                   | 4,0                               | 92,3                             | 115,3                      |
| 83,4                            | 5,0                                   | 4,0                               | 92,4                             | 115,4                      |
| 83,5                            | 4,9                                   | 4,0                               | 92,4                             | 115,4                      |
| 83,6                            | 4,8                                   | 4,0                               | 92,4                             | 115,4                      |
| 83,7                            | 4,7                                   | 4,0                               | 92,4                             | 115,4                      |
| 83,8                            | 4,7                                   | 4,0                               | 92,5                             | 115,5                      |
| 83,9                            | 4,6                                   | 4,0                               | 92,5                             | 115,5                      |
| <b>84,0</b>                     | <b>4,5</b>                            | <b>4,0</b>                        | <b>92,5</b>                      | <b>115,5</b>               |
| 84,1                            | 4,4                                   | 4,0                               | 92,5                             | 115,5                      |
| 84,2                            | 4,4                                   | 4,0                               | 92,6                             | 115,6                      |
| 84,3                            | 4,3                                   | 4,0                               | 92,6                             | 115,6                      |
| 84,4                            | 4,2                                   | 4,0                               | 92,6                             | 115,6                      |
| 84,5                            | 4,1                                   | 4,0                               | 92,6                             | 115,6                      |
| 84,6                            | 4,1                                   | 4,0                               | 92,7                             | 115,7                      |
| 84,7                            | 4,0                                   | 4,0                               | 92,7                             | 115,7                      |
| 84,8                            | 3,9                                   | 4,0                               | 92,7                             | 115,7                      |
| 84,9                            | 3,8                                   | 4,0                               | 92,7                             | 115,7                      |
| <b>85,0</b>                     | <b>3,8</b>                            | <b>4,0</b>                        | <b>92,8</b>                      | <b>115,8</b>               |
| 85,1                            | 3,7                                   | 4,0                               | 92,8                             | 115,8                      |
| 85,2                            | 3,6                                   | 4,0                               | 92,8                             | 115,8                      |
| 85,3                            | 3,5                                   | 4,0                               | 92,8                             | 115,8                      |
| 85,4                            | 3,5                                   | 4,0                               | 92,9                             | 115,9                      |
| 85,5                            | 3,4                                   | 4,0                               | 92,9                             | 115,9                      |
| 85,6                            | 3,3                                   | 4,0                               | 92,9                             | 115,9                      |

| <b>Body Weight<br/>BW in kg</b> | <b>Additional Weight<br/>AW in kg</b> | <b>Race Clothing<br/>RC in kg</b> | <b>Total Weight<br/>TW in kg</b> | <b>Total<br/>with Sled</b> |
|---------------------------------|---------------------------------------|-----------------------------------|----------------------------------|----------------------------|
| 85,7                            | 3,2                                   | 4,0                               | 92,9                             | 115,9                      |
| 85,8                            | 3,2                                   | 4,0                               | 93,0                             | 116,0                      |
| 85,9                            | 3,1                                   | 4,0                               | 93,0                             | 116,0                      |
| <b>86,0</b>                     | <b>3,0</b>                            | <b>4,0</b>                        | <b>93,0</b>                      | <b>116,0</b>               |
| 86,1                            | 2,9                                   | 4,0                               | 93,0                             | 116,0                      |
| 86,2                            | 2,9                                   | 4,0                               | 93,1                             | 116,1                      |
| 86,3                            | 2,8                                   | 4,0                               | 93,1                             | 116,1                      |
| 86,4                            | 2,7                                   | 4,0                               | 93,1                             | 116,1                      |
| 86,5                            | 2,6                                   | 4,0                               | 93,1                             | 116,1                      |
| 86,6                            | 2,6                                   | 4,0                               | 93,2                             | 116,2                      |
| 86,7                            | 2,5                                   | 4,0                               | 93,2                             | 116,2                      |
| 86,8                            | 2,4                                   | 4,0                               | 93,2                             | 116,2                      |
| 86,9                            | 2,3                                   | 4,0                               | 93,2                             | 116,2                      |
| <b>87,0</b>                     | <b>2,3</b>                            | <b>4,0</b>                        | <b>93,3</b>                      | <b>116,3</b>               |
| 87,1                            | 2,2                                   | 4,0                               | 93,3                             | 116,3                      |
| 87,2                            | 2,1                                   | 4,0                               | 93,3                             | 116,3                      |
| 87,3                            | 2,0                                   | 4,0                               | 93,3                             | 116,3                      |
| 87,4                            | 2,0                                   | 4,0                               | 93,4                             | 116,4                      |
| 87,5                            | 1,9                                   | 4,0                               | 93,4                             | 116,4                      |
| 87,6                            | 1,8                                   | 4,0                               | 93,4                             | 116,4                      |
| 87,7                            | 1,7                                   | 4,0                               | 93,4                             | 116,4                      |
| 87,8                            | 1,7                                   | 4,0                               | 93,5                             | 116,5                      |
| 87,9                            | 1,6                                   | 4,0                               | 93,5                             | 116,5                      |
| <b>88,0</b>                     | <b>1,5</b>                            | <b>4,0</b>                        | <b>93,5</b>                      | <b>116,5</b>               |
| 88,1                            | 1,4                                   | 4,0                               | 93,5                             | 116,5                      |
| 88,2                            | 1,4                                   | 4,0                               | 93,6                             | 116,6                      |
| 88,3                            | 1,3                                   | 4,0                               | 93,6                             | 116,6                      |
| 88,4                            | 1,2                                   | 4,0                               | 93,6                             | 116,6                      |
| 88,5                            | 1,1                                   | 4,0                               | 93,6                             | 116,6                      |
| 88,6                            | 1,1                                   | 4,0                               | 93,7                             | 116,7                      |
| 88,7                            | 1,0                                   | 4,0                               | 93,7                             | 116,7                      |
| 88,8                            | 0,9                                   | 4,0                               | 93,7                             | 116,7                      |
| 88,9                            | 0,8                                   | 4,0                               | 93,7                             | 116,7                      |
| <b>89,0</b>                     | <b>0,8</b>                            | <b>4,0</b>                        | <b>93,8</b>                      | <b>116,8</b>               |
| 89,1                            | 0,7                                   | 4,0                               | 93,8                             | 116,8                      |
| 89,2                            | 0,6                                   | 4,0                               | 93,8                             | 116,8                      |
| 89,3                            | 0,5                                   | 4,0                               | 93,8                             | 116,8                      |
| 89,4                            | 0,5                                   | 4,0                               | 93,9                             | 116,9                      |
| 89,5                            | 0,4                                   | 4,0                               | 93,9                             | 116,9                      |
| 89,6                            | 0,3                                   | 4,0                               | 93,9                             | 116,9                      |
| 89,7                            | 0,2                                   | 4,0                               | 93,9                             | 116,9                      |
| 89,8                            | 0,2                                   | 4,0                               | 94,0                             | 117,0                      |
| 89,9                            | 0,1                                   | 4,0                               | 94,0                             | 117,0                      |
| <b>90,0</b>                     | <b>0,0</b>                            | <b>4,0</b>                        | <b>94,0</b>                      | <b>117,0</b>               |



**Women / Junior Women / Youth A Men:**

AW = 75% of the difference between 75 kg and BW (max. 10 kg)

TW = BW + AW + 4 kg RC

| <b>Body Weight<br/>BW in kg</b> | <b>Additional Weight<br/>AW in kg</b> | <b>Race Clothing<br/>RC in kg</b> | <b>Total Weight<br/>TW in kg</b> | <b>Total<br/>with Sled</b> |
|---------------------------------|---------------------------------------|-----------------------------------|----------------------------------|----------------------------|
| 61,7                            | 10,0                                  | 4,0                               | 75,7                             | 98,7                       |
| 61,8                            | 9,9                                   | 4,0                               | 75,7                             | 98,7                       |
| 61,9                            | 9,8                                   | 4,0                               | 75,7                             | 98,7                       |
| <b>62,0</b>                     | <b>9,8</b>                            | <b>4,0</b>                        | <b>75,8</b>                      | <b>98,8</b>                |
| 62,1                            | 9,7                                   | 4,0                               | 75,8                             | 98,8                       |
| 62,2                            | 9,6                                   | 4,0                               | 75,8                             | 98,8                       |
| 62,3                            | 9,5                                   | 4,0                               | 75,8                             | 98,8                       |
| 62,4                            | 9,5                                   | 4,0                               | 75,9                             | 98,9                       |
| 62,5                            | 9,4                                   | 4,0                               | 75,9                             | 98,9                       |
| 62,6                            | 9,3                                   | 4,0                               | 75,9                             | 98,9                       |
| 62,7                            | 9,2                                   | 4,0                               | 75,9                             | 98,9                       |
| 62,8                            | 9,2                                   | 4,0                               | 76,0                             | 99,0                       |
| 62,9                            | 9,1                                   | 4,0                               | 76,0                             | 99,0                       |
| <b>63,0</b>                     | <b>9,0</b>                            | <b>4,0</b>                        | <b>76,0</b>                      | <b>99,0</b>                |
| 63,1                            | 8,9                                   | 4,0                               | 76,0                             | 99,0                       |
| 63,2                            | 8,9                                   | 4,0                               | 76,1                             | 99,1                       |
| 63,3                            | 8,8                                   | 4,0                               | 76,1                             | 99,1                       |
| 63,4                            | 8,7                                   | 4,0                               | 76,1                             | 99,1                       |
| 63,5                            | 8,6                                   | 4,0                               | 76,1                             | 99,1                       |
| 63,6                            | 8,6                                   | 4,0                               | 76,2                             | ^99,2                      |
| 63,7                            | 8,5                                   | 4,0                               | 76,2                             | 99,2                       |
| 63,8                            | 8,4                                   | 4,0                               | 76,2                             | 99,2                       |
| 63,9                            | 8,3                                   | 4,0                               | 76,2                             | 99,2                       |
| <b>64,0</b>                     | <b>8,3</b>                            | <b>4,0</b>                        | <b>76,3</b>                      | <b>99,3</b>                |
| 64,1                            | 8,2                                   | 4,0                               | 76,3                             | 99,3                       |
| 64,2                            | 8,1                                   | 4,0                               | 76,3                             | 99,3                       |
| 64,3                            | 8,0                                   | 4,0                               | 76,3                             | 99,3                       |
| 64,4                            | 8,0                                   | 4,0                               | 76,4                             | 99,4                       |
| 64,5                            | 7,9                                   | 4,0                               | 76,4                             | 99,4                       |
| 64,6                            | 7,8                                   | 4,0                               | 76,4                             | 99,4                       |
| 64,7                            | 7,7                                   | 4,0                               | 76,4                             | 99,4                       |
| 64,8                            | 7,7                                   | 4,0                               | 76,5                             | 99,5                       |
| 64,9                            | 7,6                                   | 4,0                               | 76,5                             | 99,5                       |
| <b>65,0</b>                     | <b>7,5</b>                            | <b>4,0</b>                        | <b>76,5</b>                      | <b>99,5</b>                |
| 65,1                            | 7,4                                   | 4,0                               | 76,5                             | 99,5                       |
| 65,2                            | 7,4                                   | 4,0                               | 76,6                             | 99,6                       |
| 65,3                            | 7,3                                   | 4,0                               | 76,6                             | 99,6                       |
| 65,4                            | 7,2                                   | 4,0                               | 76,6                             | 99,6                       |
| 65,5                            | 7,1                                   | 4,0                               | 76,6                             | 99,6                       |
| 65,6                            | 7,1                                   | 4,0                               | 76,7                             | 99,7                       |
| 65,7                            | 7,0                                   | 4,0                               | 76,7                             | 99,7                       |
| 65,8                            | 6,9                                   | 4,0                               | 76,7                             | 99,7                       |

| <b>Body Weight<br/>BW in kg</b> | <b>Additional Weight<br/>AW in kg</b> | <b>Race Clothing<br/>RC in kg</b> | <b>Total Weight<br/>TW in kg</b> | <b>Total<br/>with Sled</b> |
|---------------------------------|---------------------------------------|-----------------------------------|----------------------------------|----------------------------|
| 65,9                            | 6,8                                   | 4,0                               | 76,7                             | 99,7                       |
| <b>66,0</b>                     | <b>6,8</b>                            | <b>4,0</b>                        | <b>76,8</b>                      | <b>99,8</b>                |
| 66,1                            | 6,7                                   | 4,0                               | 76,8                             | 99,8                       |
| 66,2                            | 6,6                                   | 4,0                               | 76,8                             | 99,8                       |
| 66,3                            | 6,5                                   | 4,0                               | 76,8                             | 99,8                       |
| 66,4                            | 6,5                                   | 4,0                               | 76,9                             | 99,9                       |
| 66,5                            | 6,4                                   | 4,0                               | 76,9                             | 99,9                       |
| 66,6                            | 6,3                                   | 4,0                               | 76,9                             | 99,9                       |
| 66,7                            | 6,2                                   | 4,0                               | 76,9                             | 99,9                       |
| 66,8                            | 6,2                                   | 4,0                               | 77,0                             | 100,0                      |
| 66,9                            | 6,1                                   | 4,0                               | 77,0                             | 100,0                      |
| <b>67,0</b>                     | <b>6,0</b>                            | <b>4,0</b>                        | <b>77,0</b>                      | <b>100,0</b>               |
| 67,1                            | 5,9                                   | 4,0                               | 77,0                             | 100,0                      |
| 67,2                            | 5,9                                   | 4,0                               | 77,1                             | 100,1                      |
| 67,3                            | 5,8                                   | 4,0                               | 77,1                             | 100,1                      |
| 67,4                            | 5,7                                   | 4,0                               | 77,1                             | 100,1                      |
| 67,5                            | 5,6                                   | 4,0                               | 77,1                             | 100,1                      |
| 67,6                            | 5,6                                   | 4,0                               | 77,2                             | 100,2                      |
| 67,7                            | 5,5                                   | 4,0                               | 77,2                             | 100,2                      |
| 67,8                            | 5,4                                   | 4,0                               | 77,2                             | 100,2                      |
| 67,9                            | 5,3                                   | 4,0                               | 77,2                             | 100,2                      |
| <b>68,0</b>                     | <b>5,3</b>                            | <b>4,0</b>                        | <b>77,3</b>                      | <b>100,3</b>               |
| 68,1                            | 5,2                                   | 4,0                               | 77,3                             | 100,3                      |
| 68,2                            | 5,1                                   | 4,0                               | 77,3                             | 100,3                      |
| 68,3                            | 5,0                                   | 4,0                               | 77,3                             | 100,3                      |
| 68,4                            | 5,0                                   | 4,0                               | 77,4                             | 100,4                      |
| 68,5                            | 4,9                                   | 4,0                               | 77,4                             | 100,4                      |
| 68,6                            | 4,8                                   | 4,0                               | 77,4                             | 100,4                      |
| 68,7                            | 4,7                                   | 4,0                               | 77,4                             | 100,4                      |
| 68,8                            | 4,7                                   | 4,0                               | 77,5                             | 100,5                      |
| 68,9                            | 4,6                                   | 4,0                               | 77,5                             | 100,5                      |
| <b>69,0</b>                     | <b>4,5</b>                            | <b>4,0</b>                        | <b>77,5</b>                      | <b>100,5</b>               |
| 69,1                            | 4,4                                   | 4,0                               | 77,5                             | 100,5                      |
| 69,2                            | 4,4                                   | 4,0                               | 77,6                             | 100,6                      |
| 69,3                            | 4,3                                   | 4,0                               | 77,6                             | 100,6                      |
| 69,4                            | 4,2                                   | 4,0                               | 77,6                             | 100,6                      |
| 69,5                            | 4,1                                   | 4,0                               | 77,6                             | 100,6                      |
| 69,6                            | 4,1                                   | 4,0                               | 77,7                             | 100,7                      |
| 69,7                            | 4,0                                   | 4,0                               | 77,7                             | 100,7                      |
| 69,8                            | 3,9                                   | 4,0                               | 77,7                             | 100,7                      |
| 69,9                            | 3,8                                   | 4,0                               | 77,7                             | 100,7                      |
| <b>70,0</b>                     | <b>3,8</b>                            | <b>4,0</b>                        | <b>77,8</b>                      | <b>100,8</b>               |
| 70,1                            | 3,7                                   | 4,0                               | 77,8                             | 100,8                      |
| 70,2                            | 3,6                                   | 4,0                               | 77,8                             | 100,8                      |
| 70,3                            | 3,5                                   | 4,0                               | 77,8                             | 100,8                      |
| 70,4                            | 3,5                                   | 4,0                               | 77,9                             | 100,9                      |

| <b>Body Weight<br/>BW in kg</b> | <b>Additional Weight<br/>AW in kg</b> | <b>Race Clothing<br/>RC in kg</b> | <b>Total Weight<br/>TW in kg</b> | <b>Total<br/>with Sled</b> |
|---------------------------------|---------------------------------------|-----------------------------------|----------------------------------|----------------------------|
| 70,5                            | 3,4                                   | 4,0                               | 77,9                             | 100,9                      |
| 70,6                            | 3,3                                   | 4,0                               | 77,9                             | 100,9                      |
| 70,7                            | 3,2                                   | 4,0                               | 77,9                             | 100,9                      |
| 70,8                            | 3,2                                   | 4,0                               | 78,0                             | 101,0                      |
| 70,9                            | 3,1                                   | 4,0                               | 78,0                             | 101,0                      |
| <b>71,0</b>                     | <b>3,0</b>                            | <b>4,0</b>                        | <b>78,0</b>                      | <b>101,0</b>               |
| 71,1                            | 2,9                                   | 4,0                               | 78,0                             | 101,0                      |
| 71,2                            | 2,9                                   | 4,0                               | 78,1                             | 101,1                      |
| 71,3                            | 2,8                                   | 4,0                               | 78,1                             | 101,1                      |
| 71,4                            | 2,7                                   | 4,0                               | 78,1                             | 101,1                      |
| 71,5                            | 2,6                                   | 4,0                               | 78,1                             | 101,1                      |
| 71,6                            | 2,6                                   | 4,0                               | 78,2                             | 101,2                      |
| 71,7                            | 2,5                                   | 4,0                               | 78,2                             | 101,2                      |
| 71,8                            | 2,4                                   | 4,0                               | 78,2                             | 101,2                      |
| 71,9                            | 2,3                                   | 4,0                               | 78,2                             | 101,2                      |
| <b>72,0</b>                     | <b>2,3</b>                            | <b>4,0</b>                        | <b>78,3</b>                      | <b>101,3</b>               |
| 72,1                            | 2,2                                   | 4,0                               | 78,3                             | 101,3                      |
| 72,2                            | 2,1                                   | 4,0                               | 78,3                             | 101,3                      |
| 72,3                            | 2,0                                   | 4,0                               | 78,3                             | 101,3                      |
| 72,4                            | 2,0                                   | 4,0                               | 78,4                             | 101,4                      |
| 72,5                            | 1,9                                   | 4,0                               | 78,4                             | 101,4                      |
| 72,6                            | 1,8                                   | 4,0                               | 78,4                             | 101,4                      |
| 72,7                            | 1,7                                   | 4,0                               | 78,4                             | 101,4                      |
| 72,8                            | 1,7                                   | 4,0                               | 78,5                             | 101,5                      |
| 72,9                            | 1,6                                   | 4,0                               | 78,5                             | 101,5                      |
| <b>73,0</b>                     | <b>1,5</b>                            | <b>4,0</b>                        | <b>78,5</b>                      | <b>101,5</b>               |
| 73,1                            | 1,4                                   | 4,0                               | 78,5                             | 101,5                      |
| 73,2                            | 1,4                                   | 4,0                               | 78,6                             | 101,6                      |
| 73,3                            | 1,3                                   | 4,0                               | 78,6                             | 101,6                      |
| 73,4                            | 1,2                                   | 4,0                               | 78,6                             | 101,6                      |
| 73,5                            | 1,1                                   | 4,0                               | 78,6                             | 101,6                      |
| 73,6                            | 1,1                                   | 4,0                               | 78,7                             | 101,7                      |
| 73,7                            | 1,0                                   | 4,0                               | 78,7                             | 101,7                      |
| 73,8                            | 0,9                                   | 4,0                               | 78,7                             | 101,7                      |
| 73,9                            | 0,8                                   | 4,0                               | 78,7                             | 101,7                      |
| <b>74,0</b>                     | <b>0,8</b>                            | <b>4,0</b>                        | <b>78,8</b>                      | <b>101,8</b>               |
| 74,1                            | 0,7                                   | 4,0                               | 78,8                             | 101,8                      |
| 74,2                            | 0,6                                   | 4,0                               | 78,8                             | 101,8                      |
| 74,3                            | 0,5                                   | 4,0                               | 78,8                             | 101,8                      |
| 74,4                            | 0,5                                   | 4,0                               | 78,9                             | 101,9                      |
| 74,5                            | 0,4                                   | 4,0                               | 78,9                             | 101,9                      |
| 74,6                            | 0,3                                   | 4,0                               | 78,9                             | 101,9                      |
| 74,7                            | 0,2                                   | 4,0                               | 78,9                             | 101,9                      |
| 74,8                            | 0,2                                   | 4,0                               | 79,0                             | 102,0                      |
| 74,9                            | 0,1                                   | 4,0                               | 79,0                             | 102,0                      |
| <b>75,0</b>                     | <b>0,0</b>                            | <b>4,0</b>                        | <b>79,0</b>                      | <b>102,0</b>               |

**Youth A Women:**

AW = 50% of the difference between 70 kg and BW (max. 8 kg)

TW = BW + AW + 4 kg RC

| <b>Body Weight<br/>BW in kg</b> | <b>Additional Weight<br/>AW in kg</b> | <b>Race Clothing<br/>RC in kg</b> | <b>Total Weight<br/>TW in kg</b> | <b>Total<br/>with Sled</b> |
|---------------------------------|---------------------------------------|-----------------------------------|----------------------------------|----------------------------|
| <b>54,0</b>                     | <b>8,0</b>                            | <b>4,0</b>                        | <b>66,0</b>                      | <b>89,0</b>                |
| 54,1                            | 8,0                                   | 4,0                               | 66,1                             | 89,1                       |
| 54,2                            | 7,9                                   | 4,0                               | 66,1                             | 89,1                       |
| 54,3                            | 7,9                                   | 4,0                               | 66,2                             | 89,2                       |
| 54,4                            | 7,8                                   | 4,0                               | 66,2                             | 89,2                       |
| 54,5                            | 7,8                                   | 4,0                               | 66,3                             | 89,3                       |
| 54,6                            | 7,7                                   | 4,0                               | 66,3                             | 89,3                       |
| 54,7                            | 7,7                                   | 4,0                               | 66,4                             | 89,4                       |
| 54,8                            | 7,6                                   | 4,0                               | 66,4                             | 89,4                       |
| 54,9                            | 7,6                                   | 4,0                               | 66,5                             | 89,5                       |
| <b>55,0</b>                     | <b>7,5</b>                            | <b>4,0</b>                        | <b>66,5</b>                      | <b>89,5</b>                |
| 55,1                            | 7,5                                   | 4,0                               | 66,6                             | 89,6                       |
| 55,2                            | 7,4                                   | 4,0                               | 66,6                             | 89,6                       |
| 55,3                            | 7,4                                   | 4,0                               | 66,7                             | 89,7                       |
| 55,4                            | 7,3                                   | 4,0                               | 66,7                             | 89,7                       |
| 55,5                            | 7,3                                   | 4,0                               | 66,8                             | 89,8                       |
| 55,6                            | 7,2                                   | 4,0                               | 66,8                             | 89,8                       |
| 55,7                            | 7,2                                   | 4,0                               | 66,9                             | 89,9                       |
| 55,8                            | 7,1                                   | 4,0                               | 66,9                             | 89,9                       |
| 55,9                            | 7,1                                   | 4,0                               | 67,0                             | 90,0                       |
| <b>56,0</b>                     | <b>7,0</b>                            | <b>4,0</b>                        | <b>67,0</b>                      | <b>90,0</b>                |
| 56,1                            | 7,0                                   | 4,0                               | 67,1                             | 90,1                       |
| 56,2                            | 6,9                                   | 4,0                               | 67,1                             | 90,1                       |
| 56,3                            | 6,9                                   | 4,0                               | 67,2                             | 90,2                       |
| 56,4                            | 6,8                                   | 4,0                               | 67,2                             | 90,2                       |
| 56,5                            | 6,8                                   | 4,0                               | 67,3                             | 90,3                       |
| 56,6                            | 6,7                                   | 4,0                               | 67,3                             | 90,3                       |
| 56,7                            | 6,7                                   | 4,0                               | 67,4                             | 90,4                       |
| 56,8                            | 6,6                                   | 4,0                               | 67,4                             | 90,4                       |
| 56,9                            | 6,6                                   | 4,0                               | 67,5                             | 90,5                       |
| <b>57,0</b>                     | <b>6,5</b>                            | <b>4,0</b>                        | <b>67,5</b>                      | <b>90,5</b>                |
| 57,1                            | 6,5                                   | 4,0                               | 67,6                             | 90,6                       |
| 57,2                            | 6,4                                   | 4,0                               | 67,6                             | 90,6                       |
| 57,3                            | 6,4                                   | 4,0                               | 67,7                             | 90,7                       |
| 57,4                            | 6,3                                   | 4,0                               | 67,7                             | 90,7                       |
| 57,5                            | 6,3                                   | 4,0                               | 67,8                             | 90,8                       |
| 57,6                            | 6,2                                   | 4,0                               | 67,8                             | 90,8                       |
| 57,7                            | 6,2                                   | 4,0                               | 67,9                             | 90,9                       |
| 57,8                            | 6,1                                   | 4,0                               | 67,9                             | 90,9                       |
| 57,9                            | 6,1                                   | 4,0                               | 68,0                             | 91,0                       |
| <b>58,0</b>                     | <b>6,0</b>                            | <b>4,0</b>                        | <b>68,0</b>                      | <b>91,0</b>                |
| 58,1                            | 6,0                                   | 4,0                               | 68,1                             | 91,1                       |
| 58,2                            | 5,9                                   | 4,0                               | 68,1                             | 91,1                       |

| <b>Body Weight<br/>BW in kg</b> | <b>Additional Weight<br/>AW in kg</b> | <b>Race Clothing<br/>RC in kg</b> | <b>Total Weight<br/>TW in kg</b> | <b>Total<br/>with Sled</b> |
|---------------------------------|---------------------------------------|-----------------------------------|----------------------------------|----------------------------|
| 58,3                            | 5,9                                   | 4,0                               | 68,2                             | 91,2                       |
| 58,4                            | 5,8                                   | 4,0                               | 68,2                             | 91,2                       |
| 58,5                            | 5,8                                   | 4,0                               | 68,3                             | 91,3                       |
| 58,6                            | 5,7                                   | 4,0                               | 68,3                             | 91,3                       |
| 58,7                            | 5,7                                   | 4,0                               | 68,4                             | 91,4                       |
| 58,8                            | 5,6                                   | 4,0                               | 68,4                             | 91,4                       |
| 58,9                            | 5,6                                   | 4,0                               | 68,5                             | 91,5                       |
| <b>59,0</b>                     | <b>5,5</b>                            | <b>4,0</b>                        | <b>68,5</b>                      | <b>91,5</b>                |
| 59,1                            | 5,5                                   | 4,0                               | 68,6                             | 91,6                       |
| 59,2                            | 5,4                                   | 4,0                               | 68,6                             | 91,6                       |
| 59,3                            | 5,4                                   | 4,0                               | 68,7                             | 91,7                       |
| 59,4                            | 5,3                                   | 4,0                               | 68,7                             | 91,7                       |
| 59,5                            | 5,3                                   | 4,0                               | 68,8                             | 91,8                       |
| 59,6                            | 5,2                                   | 4,0                               | 68,8                             | 91,8                       |
| 59,7                            | 5,2                                   | 4,0                               | 68,9                             | 91,9                       |
| 59,8                            | 5,1                                   | 4,0                               | 68,9                             | 91,9                       |
| 59,9                            | 5,1                                   | 4,0                               | 69,0                             | 92,0                       |
| <b>60,0</b>                     | <b>5,0</b>                            | <b>4,0</b>                        | <b>69,0</b>                      | <b>92,0</b>                |
| 60,1                            | 5,0                                   | 4,0                               | 69,1                             | 92,1                       |
| 60,2                            | 4,9                                   | 4,0                               | 69,1                             | 92,1                       |
| 60,3                            | 4,9                                   | 4,0                               | 69,2                             | 92,2                       |
| 60,4                            | 4,8                                   | 4,0                               | 69,2                             | 92,2                       |
| 60,5                            | 4,8                                   | 4,0                               | 69,3                             | 92,3                       |
| 60,6                            | 4,7                                   | 4,0                               | 69,3                             | 92,3                       |
| 60,7                            | 4,7                                   | 4,0                               | 69,4                             | 92,4                       |
| 60,8                            | 4,6                                   | 4,0                               | 69,4                             | 92,4                       |
| 60,9                            | 4,6                                   | 4,0                               | 69,5                             | 92,5                       |
| <b>61,0</b>                     | <b>4,5</b>                            | <b>4,0</b>                        | <b>69,5</b>                      | <b>92,5</b>                |
| 61,1                            | 4,5                                   | 4,0                               | 69,6                             | 92,6                       |
| 61,2                            | 4,4                                   | 4,0                               | 69,6                             | 92,6                       |
| 61,3                            | 4,4                                   | 4,0                               | 69,7                             | 92,7                       |
| 61,4                            | 4,3                                   | 4,0                               | 69,7                             | 92,7                       |
| 61,5                            | 4,3                                   | 4,0                               | 69,8                             | 92,8                       |
| 61,6                            | 4,2                                   | 4,0                               | 69,8                             | 92,8                       |
| 61,7                            | 4,2                                   | 4,0                               | 69,9                             | 92,9                       |
| 61,8                            | 4,1                                   | 4,0                               | 69,9                             | 92,9                       |
| 61,9                            | 4,1                                   | 4,0                               | 70,0                             | 93,0                       |
| <b>62,0</b>                     | <b>4,0</b>                            | <b>4,0</b>                        | <b>70,0</b>                      | <b>93,0</b>                |
| 62,1                            | 4,0                                   | 4,0                               | 70,1                             | 93,1                       |
| 62,2                            | 3,9                                   | 4,0                               | 70,1                             | 93,1                       |
| 62,3                            | 3,9                                   | 4,0                               | 70,2                             | 93,2                       |
| 62,4                            | 3,8                                   | 4,0                               | 70,2                             | 93,2                       |
| 62,5                            | 3,8                                   | 4,0                               | 70,3                             | 93,3                       |
| 62,6                            | 3,7                                   | 4,0                               | 70,3                             | 93,3                       |
| 62,7                            | 3,7                                   | 4,0                               | 70,4                             | 93,4                       |
| 62,8                            | 3,6                                   | 4,0                               | 70,4                             | 93,4                       |

| Body Weight<br>BW in kg | Additional Weight<br>AW in kg | Race Clothing<br>RC in kg | Total Weight<br>TW in kg | Total<br>with Sled |
|-------------------------|-------------------------------|---------------------------|--------------------------|--------------------|
| 62,9                    | 3,6                           | 4,0                       | 70,5                     | 93,5               |
| <b>63,0</b>             | <b>3,5</b>                    | <b>4,0</b>                | <b>70,5</b>              | <b>93,5</b>        |
| 63,1                    | 3,5                           | 4,0                       | 70,6                     | 93,6               |
| 63,2                    | 3,4                           | 4,0                       | 70,6                     | 93,6               |
| 63,3                    | 3,4                           | 4,0                       | 70,7                     | 93,7               |
| 63,4                    | 3,3                           | 4,0                       | 70,7                     | 93,7               |
| 63,5                    | 3,3                           | 4,0                       | 70,8                     | 93,8               |
| 63,6                    | 3,2                           | 4,0                       | 70,8                     | 93,8               |
| 63,7                    | 3,2                           | 4,0                       | 70,9                     | 93,9               |
| 63,8                    | 3,1                           | 4,0                       | 70,9                     | 93,9               |
| 63,9                    | 3,1                           | 4,0                       | 71,0                     | 94,0               |
| <b>64,0</b>             | <b>3,0</b>                    | <b>4,0</b>                | <b>71,0</b>              | <b>94,0</b>        |
| 64,1                    | 3,0                           | 4,0                       | 71,1                     | 94,1               |
| 64,2                    | 2,9                           | 4,0                       | 71,1                     | 94,1               |
| 64,3                    | 2,9                           | 4,0                       | 71,2                     | 94,2               |
| 64,4                    | 2,8                           | 4,0                       | 71,2                     | 94,2               |
| 64,5                    | 2,8                           | 4,0                       | 71,3                     | 94,3               |
| 64,6                    | 2,7                           | 4,0                       | 71,3                     | 94,3               |
| 64,7                    | 2,7                           | 4,0                       | 71,4                     | 94,4               |
| 64,8                    | 2,6                           | 4,0                       | 71,4                     | 94,4               |
| 64,9                    | 2,6                           | 4,0                       | 71,5                     | 94,5               |
| <b>65,0</b>             | <b>2,5</b>                    | <b>4,0</b>                | <b>71,5</b>              | <b>94,5</b>        |
| 65,1                    | 2,5                           | 4,0                       | 71,6                     | 94,6               |
| 65,2                    | 2,4                           | 4,0                       | 71,6                     | 94,6               |
| 65,3                    | 2,4                           | 4,0                       | 71,7                     | 94,7               |
| 65,4                    | 2,3                           | 4,0                       | 71,7                     | 94,7               |
| 65,5                    | 2,3                           | 4,0                       | 71,8                     | 94,8               |
| 65,6                    | 2,2                           | 4,0                       | 71,8                     | 94,8               |
| 65,7                    | 2,2                           | 4,0                       | 71,9                     | 94,9               |
| 65,8                    | 2,1                           | 4,0                       | 71,9                     | 94,9               |
| 65,9                    | 2,1                           | 4,0                       | 72,0                     | 95,0               |
| <b>66,0</b>             | <b>2,0</b>                    | <b>4,0</b>                | <b>72,0</b>              | <b>95,0</b>        |
| 66,1                    | 2,0                           | 4,0                       | 72,1                     | 95,1               |
| 66,2                    | 1,9                           | 4,0                       | 72,1                     | 95,1               |
| 66,3                    | 1,9                           | 4,0                       | 72,2                     | 95,2               |
| 66,4                    | 1,8                           | 4,0                       | 72,2                     | 95,2               |
| 66,5                    | 1,8                           | 4,0                       | 72,3                     | 95,3               |
| 66,6                    | 1,7                           | 4,0                       | 72,3                     | 95,3               |
| 66,7                    | 1,7                           | 4,0                       | 72,4                     | 95,4               |
| 66,8                    | 1,6                           | 4,0                       | 72,4                     | 95,4               |
| 66,9                    | 1,6                           | 4,0                       | 72,5                     | 95,5               |
| <b>67,0</b>             | <b>1,5</b>                    | <b>4,0</b>                | <b>72,5</b>              | <b>95,5</b>        |
| 67,1                    | 1,5                           | 4,0                       | 72,6                     | 95,6               |
| 67,2                    | 1,4                           | 4,0                       | 72,6                     | 95,6               |
| 67,3                    | 1,4                           | 4,0                       | 72,7                     | 95,7               |
| 67,4                    | 1,3                           | 4,0                       | 72,7                     | 95,7               |

| <b>Body Weight<br/>BW in kg</b> | <b>Additional Weight<br/>AW in kg</b> | <b>Race Clothing<br/>RC in kg</b> | <b>Total Weight<br/>TW in kg</b> | <b>Total<br/>with Sled</b> |
|---------------------------------|---------------------------------------|-----------------------------------|----------------------------------|----------------------------|
| 67,5                            | 1,3                                   | 4,0                               | 72,8                             | 95,8                       |
| 67,6                            | 1,2                                   | 4,0                               | 72,8                             | 95,8                       |
| 67,7                            | 1,2                                   | 4,0                               | 72,9                             | 95,9                       |
| 67,8                            | 1,1                                   | 4,0                               | 72,9                             | 95,9                       |
| 67,9                            | 1,1                                   | 4,0                               | 73,0                             | 96,0                       |
| <b>68,0</b>                     | <b>1,0</b>                            | <b>4,0</b>                        | <b>73,0</b>                      | <b>96,0</b>                |
| 68,1                            | 1,0                                   | 4,0                               | 73,1                             | 96,1                       |
| 68,2                            | 0,9                                   | 4,0                               | 73,1                             | 96,1                       |
| 68,3                            | 0,9                                   | 4,0                               | 73,2                             | 96,2                       |
| 68,4                            | 0,8                                   | 4,0                               | 73,2                             | 96,2                       |
| 68,5                            | 0,8                                   | 4,0                               | 73,3                             | 96,3                       |
| 68,6                            | 0,7                                   | 4,0                               | 73,3                             | 96,3                       |
| 68,7                            | 0,7                                   | 4,0                               | 73,4                             | 96,4                       |
| 68,8                            | 0,6                                   | 4,0                               | 73,4                             | 96,4                       |
| 68,9                            | 0,6                                   | 4,0                               | 73,5                             | 96,5                       |
| <b>69,0</b>                     | <b>0,5</b>                            | <b>4,0</b>                        | <b>73,5</b>                      | <b>96,5</b>                |
| 69,1                            | 0,5                                   | 4,0                               | 73,6                             | 96,6                       |
| 69,2                            | 0,4                                   | 4,0                               | 73,6                             | 96,6                       |
| 69,3                            | 0,4                                   | 4,0                               | 73,7                             | 96,7                       |
| 69,4                            | 0,3                                   | 4,0                               | 73,7                             | 96,7                       |
| 69,5                            | 0,3                                   | 4,0                               | 73,8                             | 96,8                       |
| 69,6                            | 0,2                                   | 4,0                               | 73,8                             | 96,8                       |
| 69,7                            | 0,2                                   | 4,0                               | 73,9                             | 96,9                       |
| 69,8                            | 0,1                                   | 4,0                               | 73,9                             | 96,9                       |
| 69,9                            | 0,1                                   | 4,0                               | 74,0                             | 97,0                       |
| <b>70,0</b>                     | <b>0,0</b>                            | <b>4,0</b>                        | <b>74,0</b>                      | <b>97,0</b>                |

**Men and Junior Doubles:**

AW = 50% of the difference between 90 kg and BW (max. 10 kg)

TW = BW + AW + 4 kg RC

| <b>Body Weight<br/>BW in kg</b> | <b>Additional Weight<br/>AW in kg</b> | <b>Race Clothing<br/>RC in kg</b> | <b>Total Weight<br/>TW in kg</b> | <b>Total<br/>with Sled</b> |
|---------------------------------|---------------------------------------|-----------------------------------|----------------------------------|----------------------------|
| <b>70,0</b>                     | <b>10,0</b>                           | <b>4,0</b>                        | <b>84,0</b>                      | <b>111,0</b>               |
| 70,1                            | 9,9                                   | 4,0                               | 84,0                             | 111,0                      |
| 70,2                            | 9,9                                   | 4,0                               | 84,1                             | 111,1                      |
| 70,3                            | 9,8                                   | 4,0                               | 84,1                             | 111,1                      |
| 70,4                            | 9,8                                   | 4,0                               | 84,2                             | 111,2                      |
| 70,5                            | 9,7                                   | 4,0                               | 84,2                             | 111,2                      |
| 70,6                            | 9,7                                   | 4,0                               | 84,3                             | 111,3                      |
| 70,7                            | 9,6                                   | 4,0                               | 84,3                             | 111,3                      |
| 70,8                            | 9,6                                   | 4,0                               | 84,4                             | 111,4                      |
| 70,9                            | 9,5                                   | 4,0                               | 84,4                             | 111,4                      |
| <b>71,0</b>                     | <b>9,5</b>                            | <b>4,0</b>                        | <b>84,5</b>                      | <b>111,5</b>               |
| 71,1                            | 9,4                                   | 4,0                               | 84,5                             | 111,5                      |
| 71,2                            | 9,4                                   | 4,0                               | 84,6                             | 111,6                      |
| 71,3                            | 9,3                                   | 4,0                               | 84,6                             | 111,6                      |
| 71,4                            | 9,3                                   | 4,0                               | 84,7                             | 111,7                      |
| 71,5                            | 9,2                                   | 4,0                               | 84,7                             | 111,7                      |
| 71,6                            | 9,2                                   | 4,0                               | 84,8                             | 111,8                      |
| 71,7                            | 9,1                                   | 4,0                               | 84,8                             | 111,8                      |
| 71,8                            | 9,1                                   | 4,0                               | 84,9                             | 111,9                      |
| 71,9                            | 9,0                                   | 4,0                               | 84,9                             | 111,9                      |
| <b>72,0</b>                     | <b>9,0</b>                            | <b>4,0</b>                        | <b>85,0</b>                      | <b>112,0</b>               |
| 72,1                            | 8,9                                   | 4,0                               | 85,0                             | 112,0                      |
| 72,2                            | 8,9                                   | 4,0                               | 85,1                             | 112,1                      |
| 72,3                            | 8,8                                   | 4,0                               | 85,1                             | 112,1                      |
| 72,4                            | 8,8                                   | 4,0                               | 85,2                             | 112,2                      |
| 72,5                            | 8,7                                   | 4,0                               | 85,2                             | 112,2                      |
| 72,6                            | 8,7                                   | 4,0                               | 85,3                             | 112,3                      |
| 72,7                            | 8,6                                   | 4,0                               | 85,3                             | 112,3                      |
| 72,8                            | 8,6                                   | 4,0                               | 85,4                             | 112,4                      |
| 72,9                            | 8,5                                   | 4,0                               | 85,4                             | 112,4                      |
| <b>73,0</b>                     | <b>8,5</b>                            | <b>4,0</b>                        | <b>85,5</b>                      | <b>112,5</b>               |
| 73,1                            | 8,4                                   | 4,0                               | 85,5                             | 112,5                      |
| 73,2                            | 8,4                                   | 4,0                               | 85,6                             | 112,6                      |
| 73,3                            | 8,3                                   | 4,0                               | 85,6                             | 112,6                      |
| 73,4                            | 8,3                                   | 4,0                               | 85,7                             | 112,7                      |
| 73,5                            | 8,2                                   | 4,0                               | 85,7                             | 112,7                      |
| 73,6                            | 8,2                                   | 4,0                               | 85,8                             | 112,8                      |
| 73,7                            | 8,1                                   | 4,0                               | 85,8                             | 112,8                      |
| 73,8                            | 8,1                                   | 4,0                               | 85,9                             | 112,9                      |
| 73,9                            | 8,0                                   | 4,0                               | 85,9                             | 112,9                      |
| <b>74,0</b>                     | <b>8,0</b>                            | <b>4,0</b>                        | <b>86,0</b>                      | <b>113,0</b>               |
| 74,1                            | 7,9                                   | 4,0                               | 86,0                             | 113,0                      |



| <b>Body Weight<br/>BW in kg</b> | <b>Additional Weight<br/>AW in kg</b> | <b>Race Clothing<br/>RC in kg</b> | <b>Total Weight<br/>TW in kg</b> | <b>Total<br/>with Sled</b> |
|---------------------------------|---------------------------------------|-----------------------------------|----------------------------------|----------------------------|
| 74,2                            | 7,9                                   | 4,0                               | 86,1                             | 113,1                      |
| 74,3                            | 7,8                                   | 4,0                               | 86,1                             | 113,1                      |
| 74,4                            | 7,8                                   | 4,0                               | 86,2                             | 113,2                      |
| 74,5                            | 7,7                                   | 4,0                               | 86,2                             | 113,2                      |
| 74,6                            | 7,7                                   | 4,0                               | 86,3                             | 113,3                      |
| 74,7                            | 7,6                                   | 4,0                               | 86,3                             | 113,3                      |
| 74,8                            | 7,6                                   | 4,0                               | 86,4                             | 113,4                      |
| 74,9                            | 7,5                                   | 4,0                               | 86,4                             | 113,4                      |
| <b>75,0</b>                     | <b>7,5</b>                            | <b>4,0</b>                        | <b>86,5</b>                      | <b>113,5</b>               |
| 75,1                            | 7,4                                   | 4,0                               | 86,5                             | 113,5                      |
| 75,2                            | 7,4                                   | 4,0                               | 86,6                             | 113,6                      |
| 75,3                            | 7,3                                   | 4,0                               | 86,6                             | 113,6                      |
| 75,4                            | 7,3                                   | 4,0                               | 86,7                             | 113,7                      |
| 75,5                            | 7,2                                   | 4,0                               | 86,7                             | 113,7                      |
| 75,6                            | 7,2                                   | 4,0                               | 86,8                             | 113,8                      |
| 75,7                            | 7,1                                   | 4,0                               | 86,8                             | 113,8                      |
| 75,8                            | 7,1                                   | 4,0                               | 86,9                             | 113,9                      |
| 75,9                            | 7,0                                   | 4,0                               | 86,9                             | 113,9                      |
| <b>76,0</b>                     | <b>7,0</b>                            | <b>4,0</b>                        | <b>87,0</b>                      | <b>114,0</b>               |
| 76,1                            | 6,9                                   | 4,0                               | 87,0                             | 114,0                      |
| 76,2                            | 6,9                                   | 4,0                               | 87,1                             | 114,1                      |
| 76,3                            | 6,8                                   | 4,0                               | 87,1                             | 114,1                      |
| 76,4                            | 6,8                                   | 4,0                               | 87,2                             | 114,2                      |
| 76,5                            | 6,7                                   | 4,0                               | 87,2                             | 114,2                      |
| 76,6                            | 6,7                                   | 4,0                               | 87,3                             | 114,3                      |
| 76,7                            | 6,6                                   | 4,0                               | 87,3                             | 114,3                      |
| 76,8                            | 6,6                                   | 4,0                               | 87,4                             | 114,4                      |
| 76,9                            | 6,5                                   | 4,0                               | 87,4                             | 114,4                      |
| <b>77,0</b>                     | <b>6,5</b>                            | <b>4,0</b>                        | <b>87,5</b>                      | <b>114,5</b>               |
| 77,1                            | 6,4                                   | 4,0                               | 87,5                             | 114,5                      |
| 77,2                            | 6,4                                   | 4,0                               | 87,6                             | 114,6                      |
| 77,3                            | 6,3                                   | 4,0                               | 87,6                             | 114,6                      |
| 77,4                            | 6,3                                   | 4,0                               | 87,7                             | 114,7                      |
| 77,5                            | 6,2                                   | 4,0                               | 87,7                             | 114,7                      |
| 77,6                            | 6,2                                   | 4,0                               | 87,8                             | 114,8                      |
| 77,7                            | 6,1                                   | 4,0                               | 87,8                             | 114,8                      |
| 77,8                            | 6,1                                   | 4,0                               | 87,9                             | 114,9                      |
| 77,9                            | 6,0                                   | 4,0                               | 87,9                             | 114,9                      |
| <b>78,0</b>                     | <b>6,0</b>                            | <b>4,0</b>                        | <b>88,0</b>                      | <b>115,0</b>               |
| 78,1                            | 5,9                                   | 4,0                               | 88,0                             | 115,0                      |
| 78,2                            | 5,9                                   | 4,0                               | 88,1                             | 115,1                      |
| 78,3                            | 5,8                                   | 4,0                               | 88,1                             | 115,1                      |
| 78,4                            | 5,8                                   | 4,0                               | 88,2                             | 115,2                      |
| 78,5                            | 5,7                                   | 4,0                               | 88,2                             | 115,2                      |
| 78,6                            | 5,7                                   | 4,0                               | 88,3                             | 115,3                      |
| 78,7                            | 5,6                                   | 4,0                               | 88,3                             | 115,3                      |

| <b>Body Weight<br/>BW in kg</b> | <b>Additional Weight<br/>AW in kg</b> | <b>Race Clothing<br/>RC in kg</b> | <b>Total Weight<br/>TW in kg</b> | <b>Total<br/>with Sled</b> |
|---------------------------------|---------------------------------------|-----------------------------------|----------------------------------|----------------------------|
| 78,8                            | 5,6                                   | 4,0                               | 88,4                             | 115,4                      |
| 78,9                            | 5,5                                   | 4,0                               | 88,4                             | 115,4                      |
| <b>79,0</b>                     | <b>5,5</b>                            | <b>4,0</b>                        | <b>88,5</b>                      | <b>115,5</b>               |
| 79,1                            | 5,4                                   | 4,0                               | 88,5                             | 115,5                      |
| 79,2                            | 5,4                                   | 4,0                               | 88,6                             | 115,6                      |
| 79,3                            | 5,3                                   | 4,0                               | 88,6                             | 115,6                      |
| 79,4                            | 5,3                                   | 4,0                               | 88,7                             | 115,7                      |
| 79,5                            | 5,2                                   | 4,0                               | 88,7                             | 115,7                      |
| 79,6                            | 5,2                                   | 4,0                               | 88,8                             | 115,8                      |
| 79,7                            | 5,1                                   | 4,0                               | 88,8                             | 115,8                      |
| 79,8                            | 5,1                                   | 4,0                               | 88,9                             | 115,9                      |
| 79,9                            | 5,0                                   | 4,0                               | 88,9                             | 115,9                      |
| <b>80,0</b>                     | <b>5,0</b>                            | <b>4,0</b>                        | <b>89,0</b>                      | <b>116,0</b>               |
| 80,1                            | 4,9                                   | 4,0                               | 89,0                             | 116,0                      |
| 80,2                            | 4,9                                   | 4,0                               | 89,1                             | 116,1                      |
| 80,3                            | 4,8                                   | 4,0                               | 89,1                             | 116,1                      |
| 80,4                            | 4,8                                   | 4,0                               | 89,2                             | 116,2                      |
| 80,5                            | 4,7                                   | 4,0                               | 89,2                             | 116,2                      |
| 80,6                            | 4,7                                   | 4,0                               | 89,3                             | 116,3                      |
| 80,7                            | 4,6                                   | 4,0                               | 89,3                             | 116,3                      |
| 80,8                            | 4,6                                   | 4,0                               | 89,4                             | 116,4                      |
| 80,9                            | 4,5                                   | 4,0                               | 89,4                             | 116,4                      |
| <b>81,0</b>                     | <b>4,5</b>                            | <b>4,0</b>                        | <b>89,5</b>                      | <b>116,5</b>               |
| 81,1                            | 4,4                                   | 4,0                               | 89,5                             | 116,5                      |
| 81,2                            | 4,4                                   | 4,0                               | 89,6                             | 116,6                      |
| 81,3                            | 4,3                                   | 4,0                               | 89,6                             | 116,6                      |
| 81,4                            | 4,3                                   | 4,0                               | 89,7                             | 116,7                      |
| 81,5                            | 4,2                                   | 4,0                               | 89,7                             | 116,7                      |
| 81,6                            | 4,2                                   | 4,0                               | 89,8                             | 116,8                      |
| 81,7                            | 4,1                                   | 4,0                               | 89,8                             | 116,8                      |
| 81,8                            | 4,1                                   | 4,0                               | 89,9                             | 116,9                      |
| 81,9                            | 4,0                                   | 4,0                               | 89,9                             | 116,9                      |
| <b>82,0</b>                     | <b>4,0</b>                            | <b>4,0</b>                        | <b>90,0</b>                      | <b>117,0</b>               |
| 82,1                            | 3,9                                   | 4,0                               | 90,0                             | 117,0                      |
| 82,2                            | 3,9                                   | 4,0                               | 90,1                             | 117,1                      |
| 82,3                            | 3,8                                   | 4,0                               | 90,1                             | 117,1                      |
| 82,4                            | 3,8                                   | 4,0                               | 90,2                             | 117,2                      |
| 82,5                            | 3,7                                   | 4,0                               | 90,2                             | 117,2                      |
| 82,6                            | 3,7                                   | 4,0                               | 90,3                             | 117,3                      |
| 82,7                            | 3,6                                   | 4,0                               | 90,3                             | 117,3                      |
| 82,8                            | 3,6                                   | 4,0                               | 90,4                             | 117,4                      |
| 82,9                            | 3,5                                   | 4,0                               | 90,4                             | 117,4                      |
| <b>83,0</b>                     | <b>3,5</b>                            | <b>4,0</b>                        | <b>90,5</b>                      | <b>117,5</b>               |
| 83,1                            | 3,4                                   | 4,0                               | 90,5                             | 117,5                      |
| 83,2                            | 3,4                                   | 4,0                               | 90,6                             | 117,6                      |
| 83,3                            | 3,3                                   | 4,0                               | 90,6                             | 117,6                      |

| <b>Body Weight<br/>BW in kg</b> | <b>Additional Weight<br/>AW in kg</b> | <b>Race Clothing<br/>RC in kg</b> | <b>Total Weight<br/>TW in kg</b> | <b>Total<br/>with Sled</b> |
|---------------------------------|---------------------------------------|-----------------------------------|----------------------------------|----------------------------|
| 83,4                            | 3,3                                   | 4,0                               | 90,7                             | 117,7                      |
| 83,5                            | 3,2                                   | 4,0                               | 90,7                             | 117,7                      |
| 83,6                            | 3,2                                   | 4,0                               | 90,8                             | 117,8                      |
| 83,7                            | 3,1                                   | 4,0                               | 90,8                             | 117,8                      |
| 83,8                            | 3,1                                   | 4,0                               | 90,9                             | 117,9                      |
| 83,9                            | 3,0                                   | 4,0                               | 90,9                             | 117,9                      |
| <b>84,0</b>                     | <b>3,0</b>                            | <b>4,0</b>                        | <b>91,0</b>                      | <b>118,0</b>               |
| 84,1                            | 2,9                                   | 4,0                               | 91,0                             | 118,0                      |
| 84,2                            | 2,9                                   | 4,0                               | 91,1                             | 118,1                      |
| 84,3                            | 2,8                                   | 4,0                               | 91,1                             | 118,1                      |
| 84,4                            | 2,8                                   | 4,0                               | 91,2                             | 118,2                      |
| 84,5                            | 2,7                                   | 4,0                               | 91,2                             | 118,2                      |
| 84,6                            | 2,7                                   | 4,0                               | 91,3                             | 118,3                      |
| 84,7                            | 2,6                                   | 4,0                               | 91,3                             | 118,3                      |
| 84,8                            | 2,6                                   | 4,0                               | 91,4                             | 118,4                      |
| 84,9                            | 2,5                                   | 4,0                               | 91,4                             | 118,4                      |
| <b>85,0</b>                     | <b>2,5</b>                            | <b>4,0</b>                        | <b>91,5</b>                      | <b>118,5</b>               |
| 85,1                            | 2,4                                   | 4,0                               | 91,5                             | 118,5                      |
| 85,2                            | 2,4                                   | 4,0                               | 91,6                             | 118,6                      |
| 85,3                            | 2,3                                   | 4,0                               | 91,6                             | 118,6                      |
| 85,4                            | 2,3                                   | 4,0                               | 91,7                             | 118,7                      |
| 85,5                            | 2,2                                   | 4,0                               | 91,7                             | 118,7                      |
| 85,6                            | 2,2                                   | 4,0                               | 91,8                             | 118,8                      |
| 85,7                            | 2,1                                   | 4,0                               | 91,8                             | 118,8                      |
| 85,8                            | 2,1                                   | 4,0                               | 91,9                             | 118,9                      |
| 85,9                            | 2,0                                   | 4,0                               | 91,9                             | 118,9                      |
| <b>86,0</b>                     | <b>2,0</b>                            | <b>4,0</b>                        | <b>92,0</b>                      | <b>119,0</b>               |
| 86,1                            | 1,9                                   | 4,0                               | 92,0                             | 119,0                      |
| 86,2                            | 1,9                                   | 4,0                               | 92,1                             | 119,1                      |
| 86,3                            | 1,8                                   | 4,0                               | 92,1                             | 119,1                      |
| 86,4                            | 1,8                                   | 4,0                               | 92,2                             | 119,2                      |
| 86,5                            | 1,7                                   | 4,0                               | 92,2                             | 119,2                      |
| 86,6                            | 1,7                                   | 4,0                               | 92,3                             | 119,3                      |
| 86,7                            | 1,6                                   | 4,0                               | 92,3                             | 119,3                      |
| 86,8                            | 1,6                                   | 4,0                               | 92,4                             | 119,4                      |
| 86,9                            | 1,5                                   | 4,0                               | 92,4                             | 119,4                      |
| <b>87,0</b>                     | <b>1,5</b>                            | <b>4,0</b>                        | <b>92,5</b>                      | <b>119,5</b>               |
| 87,1                            | 1,4                                   | 4,0                               | 92,5                             | 119,5                      |
| 87,2                            | 1,4                                   | 4,0                               | 92,6                             | 119,6                      |
| 87,3                            | 1,3                                   | 4,0                               | 92,6                             | 119,6                      |
| 87,4                            | 1,3                                   | 4,0                               | 92,7                             | 119,7                      |
| 87,5                            | 1,2                                   | 4,0                               | 92,7                             | 119,7                      |
| 87,6                            | 1,2                                   | 4,0                               | 92,8                             | 119,8                      |
| 87,7                            | 1,1                                   | 4,0                               | 92,8                             | 119,8                      |
| 87,8                            | 1,1                                   | 4,0                               | 92,9                             | 119,9                      |
| 87,9                            | 1,0                                   | 4,0                               | 92,9                             | 119,9                      |

| <b>Body Weight<br/>BW in kg</b> | <b>Additional Weight<br/>AW in kg</b> | <b>Race Clothing<br/>RC in kg</b> | <b>Total Weight<br/>TW in kg</b> | <b>Total<br/>with Sled</b> |
|---------------------------------|---------------------------------------|-----------------------------------|----------------------------------|----------------------------|
| <b>88,0</b>                     | <b>1,0</b>                            | <b>4,0</b>                        | <b>93,0</b>                      | <b>120,0</b>               |
| 88,1                            | 0,9                                   | 4,0                               | 93,0                             | 120,0                      |
| 88,2                            | 0,9                                   | 4,0                               | 93,1                             | 120,1                      |
| 88,3                            | 0,8                                   | 4,0                               | 93,1                             | 120,1                      |
| 88,4                            | 0,8                                   | 4,0                               | 93,2                             | 120,2                      |
| 88,5                            | 0,7                                   | 4,0                               | 93,2                             | 120,2                      |
| 88,6                            | 0,7                                   | 4,0                               | 93,3                             | 120,3                      |
| 88,7                            | 0,6                                   | 4,0                               | 93,3                             | 120,3                      |
| 88,8                            | 0,6                                   | 4,0                               | 93,4                             | 120,4                      |
| 88,9                            | 0,5                                   | 4,0                               | 93,4                             | 120,4                      |
| <b>89,0</b>                     | <b>0,5</b>                            | <b>4,0</b>                        | <b>93,5</b>                      | <b>120,5</b>               |
| 89,1                            | 0,4                                   | 4,0                               | 93,5                             | 120,5                      |
| 89,2                            | 0,4                                   | 4,0                               | 93,6                             | 120,6                      |
| 89,3                            | 0,3                                   | 4,0                               | 93,6                             | 120,6                      |
| 89,4                            | 0,3                                   | 4,0                               | 93,7                             | 120,7                      |
| 89,5                            | 0,2                                   | 4,0                               | 93,7                             | 120,7                      |
| 89,6                            | 0,2                                   | 4,0                               | 93,8                             | 120,8                      |
| 89,7                            | 0,1                                   | 4,0                               | 93,8                             | 120,8                      |
| 89,8                            | 0,1                                   | 4,0                               | 93,9                             | 120,9                      |
| 89,9                            | 0,0                                   | 4,0                               | 93,9                             | 120,9                      |
| <b>90,0</b>                     | <b>0,0</b>                            | <b>4,0</b>                        | <b>94,0</b>                      | <b>121,0</b>               |

## Supplement 3

### Rules for Instruction of International Judge

#### 1. Basics

- 1.1 The training regulation of the FIL is an obligatory work document for all National Federations associated with the FIL.
- 1.2 During all FIL competitions, judges from the respective NFs may only be appointed if they possess FIL International Judge Licenses acquired in accordance with these instruction regulations.
- 1.3 The NFs associated with the FIL have the right to conduct the instruction and qualification of international judges under their own responsibility.
- 1.4 Only persons who are full members of NFs associated with the FIL may be admitted to instruction and qualification as an international judge.
- 1.5 Issuing of the International Judge License to the applicant is made after a valid examination (test).
- 1.6 The FIL may withdraw an International Judge License for gross infractions against sportsmanship like ethics and morals in the conduct of ones duties.

#### 2. Instruction

- 2.1 The task of the NF is to select qualified persons who may be enrolled for instruction and qualification by the NFs for the International Judge License.  
The number of international judges instructed by a NF is not limited.
- 2.2 For instruction and qualification, the NF must appoint a head instructor and two assistants who have the necessary specialized knowledge to instruct the applicants.
- 2.3 The instruction and qualification must be under the supervision of the NF in accordance with the lesson plan of these instruction regulations and must not be under the prescribed 22 hours of instruction.
- 2.4 The period of instruction and qualification may not exceed six months measured from the beginning of instruction to the conclusion of the test.

#### 3. Lesson Plan

- 3.1 All sections of the IRO.
- 3.2 All supplements of the IRO.
- 3.3 Practical work with measuring devices.
- 3.4 Working during a FIL competition with the assignment of special tasks and discussions.

#### 4. Composition of the Examination Commission

- 4.1 FIL representative (proctor)
- 4.2 Chairperson of the Examination Commission
- 4.3 First assistant to the chairperson
- 4.4 Second assistant to the chairperson

**5. Responsibilities of the Examination Commission**

- 5.1 An Examination Commission is appointed by the NF to administer the final examination to the applicants.  
As a rule, the head instructor should belong to this commission.
- 5.2 The chairperson of the Examination Commission must inform the judge representative of the FIL of the examination date at least eight (8) weeks in advance of the examination so that the FIL proctor may be named and confirmed in writing to the NF.  
Expenses for the travel and accommodations of the FIL proctor are assumed by the NF.
- 5.3 A record is to be made concerning the results of the examination and its execution.  
This report must include the signatures of the Examination Commission and the FIL proctor with notation of the place and date of the examination.
- 5.4 The FIL proctor has to send this record to the judge representative of the FIL.

**6. Examination Regulations**

- 6.1 The examination is given in written and oral form.  
The examination documents are available from the judge representative of the FIL.
- 6.2 The Examination Commission determines the length of time for the examination.
- 6.3 Candidates who use external aids during the examination which seriously put their knowledge or ability into question will be disqualified.
- 6.4 The examination is passed when the applicant responds correctly to at least three quarters of the posed questions.
- 6.5 With the approval of the President of the FIL, a special examination may be conducted for a national coach who has been in this position for many years.

**7. Issuance of the International Judge License**

- 7.1 The representative of the FIL issues the International Judge License and the International Judge Badge to the applicants in question after they have successfully passed the examination.
- 7.2 The FIL distributes the International Judge License in the form of a passport identification booklet signed by the FIL President.
- 7.3 The names of FIL international judges are entered in the FIL Directory of International Officials according to their names and National Federation.
- 7.4 The FIL member NFs must grant international judges free entry to FIL competitions upon presentation of their identification card even if they are not working at the event(s).
- 7.5 The FIL Executive Board can withdraw the International Judge License from a judge, if he/she engages himself/herself in activities which harm the reputation of the FIL.

## Supplement 4

### Regulations for Audio-Visual Media Rights

#### 1. General

- 1.1 The aim of the FIL is to promote the sport of luge worldwide. In order to come up to this challenge, it is necessary to establish uniform regulations for the coverage of the sport of luge via television, film and other new media (for example Internet) in order to achieve best and worldwide media presence.
- 1.2 If there are no other regulations, the FIL is the exclusive and worldwide owner of the rights for audio-visual media for all events taking place on behalf of or with the approval of the FIL. The following rights belong to the subject audio-visual media:
- ◆ television (free or pay TV, all kinds of broadcasting, terrestrial, cable, satellite, etc.)
  - ◆ film (all formats)
  - ◆ video (all systems including video games, etc.)
  - ◆ projection rights
  - ◆ movie and video pictures on the internet
- 1.3 If these regulations are not considered, the respective competition can be cancelled from the international FIL sport calendar for a certain period to be determined by the FIL Executive Board and/or it can result in sanctions against the respective NF.

#### 2. Award of Television Rights

##### 2.1 **International Competitions (with the exception of championships)**

- 2.1.1 The FIL authorizes the NFs affiliated with the FIL to conclude contracts about the award of the television rights which concern television broadcasts of luge events - except FIL Championships and Olympic Winter Games - which the Federation organizes in its country for the broadcasting area within its own country. The NF can delegate this responsibility to individual organizations belonging to the Federation. For the handing over of television rights to television companies outside the organizing country, the FIL is solely responsible.
- 2.1.2 Prior to signing them, all contract drafts are to be presented to the FIL for approval. The FIL can only withhold its approval due to an important reason. An important reason would be if the contract partner cannot furnish production and/or broadcasting guarantees (in sufficient technical quality) and/or the contract partner does not provide an international live signal. If within six months prior to the event no detailed contract offer is presented, the FIL reserves the rights and the award of them for itself.
- 2.1.3 The NF or the event organizer authorized by the NF is obliged to grant the FIL free access to the live signal (signal with graphics and voice according to international standard).

##### 2.2 **Championships**

Regarding an agreement with television stations concerning the broadcasting rights of FIL Championships, the FIL Executive Board acts together with the organizing NF. The FIL Executive Board makes the final resolution.

##### 2.3 **Olympic Winter Games**

Agreements regarding the broadcasting rights of the Olympic Winter Games are the responsibility of the IOC.

- 2.4 **Commentator Booths**  
The NF or the event organizer authorized by the NF has to guarantee the FIL that sufficient commentator booths are available.
3. **Video, Film, and Other Rights**  
After agreement by the FIL, the NF is authorized by the FIL, to award the film and video rights in their own country, as long as it is guaranteed that marketing these rights abroad is not possible.
4. **Short Reports**  
The award of short report rights has to be done according to national and international regulations. If a respective request is made at the recording station, the FIL has to be informed at once.
5. **Financial Regulation**
- 5.1 **Television**  
For Championships, the FIL is obliged to give 2/3rds of the net income of the sales of the television rights (after deduction of possible taxes or other issue-related expenses) to the organizing NF.
- 5.2 **Video**  
The FIL has to give 2/3rds of the income of the selling of commercial film and video rights to the organizing NF.
6. **Miscellaneous**  
These regulations were acknowledged during the FIL Congress in Rome on June 24-25, 1994, and they were more precisely worded by the Congress in Colorado Springs in May 1998.



## Supplement 5

### Olympic Rules

#### 1. Validity

For the luge competitions during Olympic Winter Games (OWS), the stipulations of the International Luge Regulations (IRO) are valid.

The following additional rules are valid for the OWS:

##### 1.1 **Competition Runs**

- ♦ singles: 4
- ♦ doubles: 2

##### 1.2 **Start Order**

Singles (women and men)

|         |   |             |             |                      |
|---------|---|-------------|-------------|----------------------|
| 1st run | 1 - 12 (A)  | 13 - 24 (B) | 25 - 36 (C) | 37 to last start no. |
| 2nd run | 12 - 1 (A)  | 24 - 13 (B) | 36 - 25 (C) | last start no. to 37 |
| 3rd run | 1 - last place (according to placing after 2nd run) |             |             |                      |
| 4th run | last place to best place (after 3rd run).           |             |             |                      |

Track preparation before the best 15 athletes.

Doubles

|         |   |             |             |                      |
|---------|---|-------------|-------------|----------------------|
| 1st run | 1 - 12 (A)                                | 13 - 24 (B) | 25 - 36 (C) | 37 to last start no. |
| 2nd run | last place to best place (after 1st run). |             |             |                      |

Track preparation before the best 15 doubles teams if required.

##### 1.3 **Maximum Numbers of Participants per National Federation**

- ♦ women 3
- ♦ men 3
- ♦ doubles 2

##### 1.4 **Education of International Judges**

The Organizing Committee (OC) of the Olympic Winter Games is responsible for the education of the judges appointed for the Olympic Winter Games and has to take care of the respective expenses.

##### 1.5 **Advertising Regulations**

The regulations of the IOC are valid.

##### 1.6 **Nominations / Entry Fee**

According to the regulations of the IOC, the nominations have to be made by the NOC responsible to the OC on the stipulated dates.

The Executive Board of the FIL is to be constantly informed on the nominations by the OC.

No entry fee has to be paid.

##### 1.7 **Control Weigh-in**

The control weigh-in of the additional weight and race clothing, the control of the runners as well as the measuring of the sled and the seat (pod) take place at the finish as follows:

|          |                 |  |
|----------|-----------------|--|
| Singles: | 1st and 3rd run | - 6 drawn athletes, 3 of them from group A         |
|          | 2nd and 4th run | - no controls                                      |
| Doubles: | 1st run         | - 3 drawn athletes, one athlete from a double each |
|          | 2nd run         | - no controls                                      |

- 1.8 **Withdrawal Due to Injury / Sickness**  
 If during training an athlete who is nominated for the participation in the singles discipline withdraws due to injury / sickness, then another athlete who belongs to the Olympic team and has completed the minimum number of training runs can be nominated instead.
- 1.9 **Training**  
 The Olympic training will be regulated as follows:
- ◆ 1 systematic training run
  - ◆ 6 training runs per discipline over 3 days
  - ◆ 1st training day, training by groups according to draw by NFs
  - ◆ 2<sup>nd</sup> training day, training by groups in reversed order
  - ◆ 3<sup>rd</sup> training day, joint training according to new draw by NFs
    - 1<sup>st</sup> training run first to last, track maintenance, 2<sup>nd</sup> training run last to first in accordance with the draw.
  - ◆ Doubles drivers who participate in singles training can not participate in singles training assigned to doubles drivers, and they get no systematic run in doubles.
    - In case only one athlete from a doubles team participates in singles training, the doubles team can take the systematic run in doubles.
- If a time difference of two (2) or more days exists between two (2) race runs of a discipline, then at least one (1) training run must be added for the athletes participating in the competition before the next race run.
- If a time difference of two (2) or more days exists between two (2) training runs, then one additional training run must be offered for the athletes participating in the competition.
- 1.10 **International Training Courses on the Olympic Track**  
 The organizer of the Olympic luge competitions are obligated before the Olympic Winter Games to offer two international training weeks for all NFs.  
 At least 6 training days with at least 3 training runs per day are to be made available in each week. The Executive Board of the FIL will decide on possible training restrictions during the Olympic season.
- 1.11 **Test Race**  
 One year prior to the OWS, the track has to be available to the FIL for a test competition open to all NFs.  
 The members of the jury and the technical delegates of the FIL present at the test race have to examine the track regarding its safety and the technical facilities.  
 The OC and the staging NF has to be informed on the result of the test race in writing.  
 Complaints and damage have to be fully remedied prior to the staging of the OWS.
2. **Preparation and Staging**
- 2.1 **The FIL as Highest Body**  
 The FIL is responsible to the IOC for the proper staging of luge competitions.  
 The FIL is the highest body of these competitions. In order to meet this task, the FIL appoints and sends the following persons at the expense of the OC during the staging of the Olympic luge program:
- ◆ the President and the General Secretary (they officially represent the FIL),
  - ◆ the jury, consisting of the chairperson and two members,
  - ◆ the technical delegates, consisting of three persons,
  - ◆ additional international judges
    - (the number is coordinated between the IOC, the OC and the FIL)
  - ◆ two IOC technical delegates who have to provide the permanent contact to the IOC.
- For the jury, technical delegates, and IOC technical delegates, walkie-talkies with independent frequencies have to be provided.

2.2 **Responsibility of the National Federation**

The National Federation in cooperation with the OC of the OWS is responsible for the organization of the Olympic luge competitions.

A permanent and close cooperation between the National Federation, OC and the FIL starting with the preparation work until the completion of the Olympic luge competitions is necessary.

A sport office / luge department has to be provided by the OC for the luge competitions and a full-time director has to be appointed.

The National Federation responsible must be represented in a leadership position by its president or by an elected chairperson.

2.3 **Officials, Judges, Assistants**

Each NF hosting Olympic luge competitions should have approximately 30 international judges who should already be working during the pre-olympic test.

The FIL supports the required education and training. Judges who have important tasks during the OWS (race leader, start and finish leader, chief of track and their representatives) should gain experience already prior to the OWS during important FIL competitions.

The following officials / judges / assistants are required for the Olympic luge competitions:

- ♦ organizing chairperson
- ♦ assistant chairperson
- ♦ 3 - 6 officials in the luge sport office / luge department
- ♦ press chief
- ♦ race director
- ♦ assistant race director
- ♦ start leader
- ♦ assistant start leader
- ♦ starter
- ♦ start telephonist
- ♦ finish leader
- ♦ assistant finish leader
- ♦ person in charge of weigh in
- ♦ chief of track
- ♦ assistant track chief
- ♦ chief of timing
- ♦ assistant chief of timing
- ♦ 2 persons to control the temperature of the runners
- ♦ 2 persons to keep the records of this control
- ♦ chief of transport
- ♦ hosts/hostesses
- ♦ announcer for the track loudspeaker system
- ♦ 2 persons for the scoreboard
- ♦ 2 - 3 translators
- ♦ 2 officials for the work shop
- ♦ controller for time-keeping
- ♦ recorder for weigh-in
- ♦ assistant for weigh-in
- ♦ assistant for announcer
- ♦ 2 - 4 assistants at the start
- ♦ 2 - 4 assistants at the finish
- ♦ 4 - 8 persons for check-points at the track
- ♦ track workers for track building and maintenance

Total required: approximately 50 - 70 persons.

If the weather conditions are unfavourable, approximately 50 additional persons are required to work at the track (snow removal, etc.).

- 2.4 **Program / Time Schedule**  
By paying attention to the overall planning of the Olympic Winter Games, the organizers (OC and NF) propose the detailed Olympic luge schedule to the FIL in time.  
The schedule has to be approved by the FIL Executive Board.  
Changes which are determined by the FIL Executive Board are binding and have to be met by the organizers (OC).
- 2.5 **Interpreters**  
A sufficient number of interpreters fluent in German and English have to be available for the officials.
3. **Luge Tracks**  
In general, Olympic luge competitions are staged on combined bobsleigh and luge tracks (artificial tracks with or without technical facilities for artificial refrigeration).  
The "Regulation for Artificial Luge Tracks" (Supplement 1) is valid.
4. **Eligibility Rules**  
With regard to permission to participate in the Olympic Winter Games, the qualification criteria as agreed on and amended by the FIL and the IOC will apply.  
In individual and justified cases, the FIL Executive Board can make exceptions.
5. **Doping Controls**  
The regulations of the IOC are valid.